



杰牌官方网站
JIE Website



杰牌官方微信
JIE Wechat



杰牌始创于1988年,坚持100年做好一台减速机,匠心打造齿轮行业百年企业。
杰牌减速机+电动机+变频器+传感器+物联网等智能传动方案,服务全球市场,杰牌为全球好客户做好产品。
杰牌坚持“专业化、智能化、全球化”发展规划,致力于智能工厂、智能产品、智能服务、智能体验、智能人才等工业4.0技术的创新与应用。
杰牌智能传动方案提供商!

Established in 1988, JIE has been insisting on manufacturing a great reducer in 100 years, aiming to build a century-old enterprise with its craftsmanship.
JIE serves global market with intelligent drive solutions incl. gear units, motors, inverters, sensors and Internet of Things. JIE is committed to providing great products for great partners across the world.
With the core strategy of "Specialization, Intelligence and Globalization", JIE is dedicated to the innovation and application of industry 4.0 technologies incl. intelligent plants, intelligent products, intelligent services, intelligent experiences, intelligent talents, etc.
JIE, a provider of Intelligent Drive Solutions!



杰牌传动
JIE DRIVE



JCS、JDC伺服系统
JCS、JDC Servo System



杭州杰牌传动科技有限公司
HANG ZHOU JIE DRIVE TECHNOLOGY CO.,LTD.

地址 Add: 中国杭州萧山·杭州空港经济区·杰牌路1号 邮编: 311223
No.1, JIE Road, Hangzhou Airport Economic Zone, Xiaoshan,
311223, Hangzhou, P.R. China

热线 Tel: +86 571 8299 1111 400 114 1111

总机 Call Center: +86 571 8299 2222

传真 Fax: +86 571 8299 3333

邮箱 E mail: jie@jie.com.cn

网址 Web: www.jie.com.cn www.jiedrive.com

JIE USA, INC.

Add : 493 Mission St. Carol Stream IL 60188 USA

Tel : +1 630 580 9986

E-mail: info@jie-drives.com

Web : www.jie-drives.com

版权号: 国作登字-2020-L-01077078 版本号: JIEC·09-01A·2020A·1000
法律声明: 本画册及产品目录中的所有产品和图片,包括但不限于产品设计、外观、材料、颜色、包装、图纸、数据、技术规范等内容,已申请并
获得授权或注册相关知识产权,受相关法律法规的保护。杰牌享有本画册和产品目录及其所载内容、信息的知识产权。未经许可,不得复制、抄袭或以其他方式使用。
Legal Notices: JIE obtained the authorization or relevant intellectual property against all the products or photos in this catalogue including but not limited to the design, appearance,
material, color, packing, drawing, data, technical specification, etc. and is protected by relevant laws and regulations. If without permission, it is forbidden to copy, plagiarize or use for other purpose.

因专业 而杰出
Excellence From Expertise

杰牌智能传动方案提供商

JIE INTELLIGENT DRIVE SOLUTIONS PROVIDER

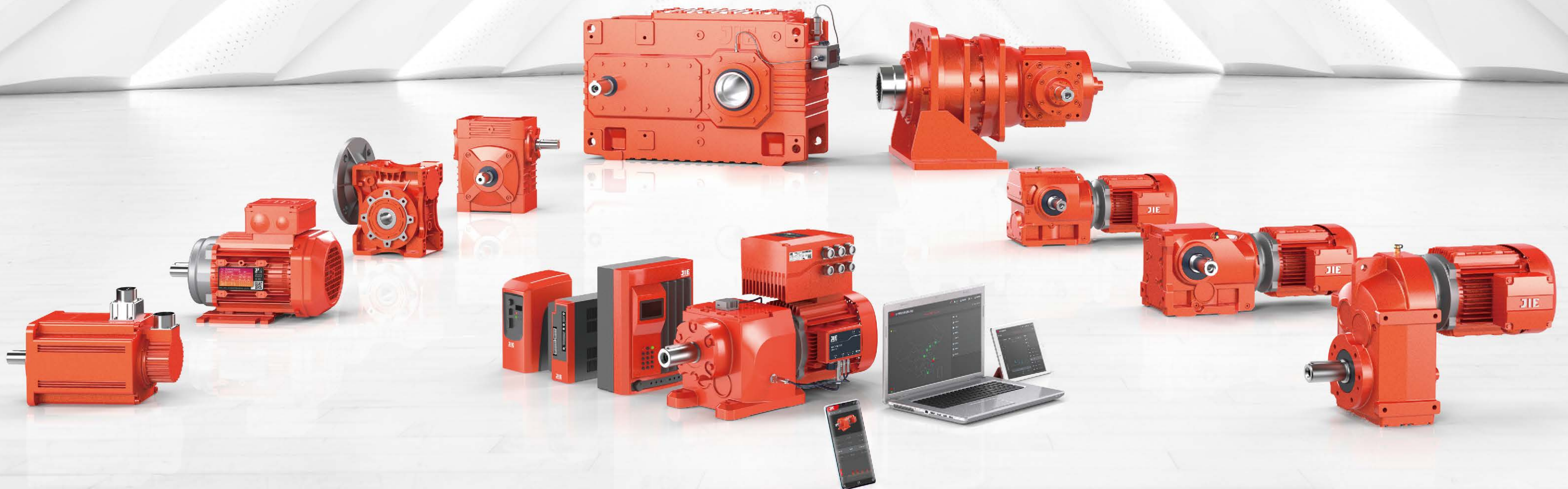

JIE
JD RIVE

旭
日
东
升
生
机
盎
然
万
物
之
灵
天
地
之
杰



目 录

P6-7	一. 选型步骤
P8	二. 产品图片
P9-11	三. 产品说明
P12-13	四. 产品结构
P14-17	五. 选型说明
P18-25	六. 电机技术参数
P26-31	七. 驱动器技术参数
P32-36	八. 系统配置
P37-40	九. 产品附件
P41-43	十. 伺服系统订货指南
P45-52	杰牌传动产品目录

CONTENTS

P6-7	Selection Guide
P8	Product Pictures
P9-11	Product Description
P12-13	Product Structure
P14-17	Selection Description
P18-25	Motor Electrical Parameters
P26-31	Drive Electrical Parameters
P32-36	System Constructure
P37-40	Product Accessories
P41-43	Order Information
P45-52	JIE Drive Product Catalogue

一. 选型步骤

Selection Guide

- | | | |
|----|--|--|
| 1 | <p>选择杰牌传动产品</p> <p>例: JDC 小惯量伺服电机、中惯量伺服电机等信息。</p> | <p>Select JIE Drive products</p> <p>Example: Pick the right model, according to application, select the JDC low inertia or middle inertia servo motor.</p> |
| 2 | <p>输入现用产品品牌</p> <p>例: 杰牌传动、欧美日品牌、中国品牌等信息。</p> | <p>Enter current product brand</p> <p>Example: JIE Drive or competitors.</p> |
| 3 | <p>输入现用产品参数</p> <p>例: JDC 伺服电机法兰尺寸规格60~180mm, 额定功率0.4~7.5kW, 额定输出扭矩1.27~48Nm, 抱闸, 编码器类型, 伺服驱动器功率和控制方式等型号规格信息。</p> | <p>Enter current product specifications</p> <p>Example: JDC servo motor frame size 60~180mm, rated power 0.4~7.5kW, rated output torque 1.27~48Nm, with or without brake, types of encoder and other specifications.</p> |
| 4 | <p>生成杰牌产品型号规格</p> <p>例: JDC130M-1K0204M-BOKA等电机型号信息。
JCS500-1K0-4V-PN0A1S等驱动器型号信息。</p> | <p>Generate JIE Drive model and specifications</p> <p>Example: Motor model JDC130M-1K0204M-BOKA, Drive model JCS500-1K0-4V-PN0A1S and other information.</p> |
| 5 | <p>生成杰牌产品2D/3D图</p> <p>例: JDC130M-1K0204M-BOKA等产品2D/3D图信息, JCS500-1K0-4V-PN0A1S等产品2D/3D图信息。</p> | <p>Generate 2D/3D drawings of JIE Drive products</p> <p>Example: 2D/3D drawings of motor JDC130M-1K0204M-BOKA and drive JCS500-1K0-4V-PN0A1S information.</p> |
| 6 | <p>确认技术质量标准</p> <p>例: 技术质量标准按杰牌相关标准和双方协议约定的标准执行, 质保期自发货之日起18个月或实际使用之日起12个月, 以先到为准等信息确认。</p> | <p>Confirm the technical quality standard</p> <p>Example: The technical and quality standards shall be implemented according to the relevant standards of JIE Drive and the standards agreed by both parties. The warranty period shall be 12 months after start using products or 18 months after shipment from JIE whichever comes earlier.</p> |
| 7 | <p>确认交期服务类等信息</p> <p>例: 首次合作按双方协议约定时间交货, 提供1+3滚动计划时7天交货; 总用量、年用量、月用量、批用量、试用量; 售前服务、售中服务、售后服务、预单管理等信息确认。</p> | <p>Confirm delivery standard</p> <p>Example: Delivery shall be made according to the time agreed by both parties for the first cooperation; 7 days lead time base on 1+3 rolling plan, including total usage, annual usage, monthly usage, batch usage and sample; confirmation of pre-sales service, in-sales service, after-sales service and pre-order management.</p> |
| 8 | <p>确认结算价格类等信息</p> <p>例: 30%定金款到后订单生效, 余款款到后发货; 价格按双方协议约定的价格执行等信息。</p> | <p>Confirm the settlement price standard</p> <p>Example: The order comes into effective after 30% deposition received and products will be delivered after balance payment; price shall be subject to agreed upon both parties.</p> |
| 9 | <p>确认产品订单信息</p> <p>例: 产品名称、型号规格、技术参数、订单数量、包装形式、运输方式、下单时间、交付时间、交付地点、收货单位等信息确认。</p> | <p>Confirm order information</p> <p>Example: Confirm product type, model, specification, order quantity, packaging, transportation, P.O issue time, delivery time, delivery location, receiving company and other order information.</p> |
| 10 | <p>确认产品交付等信息</p> <p>例: 样机订单交付、小批订单交付、批量订单交付等信息确认。</p> | <p>Confirm product delivery information</p> <p>Example: Confirm prototype delivery, small batch delivery, batch delivery and other delivery information.</p> |

生成杰牌产品2D/3D图 Generate 2D/3D drawing of JIE products

型号	JD 3500-100-4V-FN0A5
额定电压(V)	380
额定功率(W)	1
额定转矩(Nm)	2000
最大转矩(Nm)	3000
额定速度(rpm)	478
额定电流(A)	2.8
绝缘等级	F/55
防护等级	IP55
电机重量(kg)	8.3
冷却方式	23℃自然冷却
结构	悬
重量(kg)	7.5

名称		
标准尺寸		
定制尺寸		

序号	1	2	3
名称			

名称		
标准性能		
定制性能		

品牌	JIE
系列	JD 3500
名称	JDC伺服电机
型号	JD 3500-100-4V-FN0A5
结构	

型号	JCS500-100-4V-FN0A5
额定电压(V)	3P AC380V
额定功率(W)	47-63
额定转矩(Nm)	1
额定速度(rpm)	350
额定电流(A)	PROFNET总线
冷却方式	0-45
防护等级	IP 20

名称		
标准尺寸		
定制尺寸		

序号	1	2	3
名称			

名称		
标准性能		
定制性能		

品牌	JIE
系列	JD 3500
名称	JCS伺服驱动器
型号	JCS500-100-4V-FN0A5
结构	

二. 产品图片 Product Pictures



三. 产品说明

Product Description

1. JCS、JDC伺服系统

JCS、JDC Servo System

产品说明 Product Description

杰牌JCS、JDC智能伺服系统，拥有自主知识产权，产品具有外观美、控制精度高、易于使用、运行可靠和智能化等亮点，为客户提供包括JCS伺服驱动器(脉冲型、总线型)和JDC伺服电机(小惯量、中惯量)等全系列产品。

杰牌JCS、JDC智能伺服系统，通过完整产品策划与设计 and 全价值链精益生产最优方案实施，推进精益生产、建设智能工厂，实现研产供销服一体化，以满足客户对快速响应的需求。

杰牌JCS、JDC智能伺服系统，遵循模块化和最优化设计理念，系列产品采用集成电源串接端子、工业以太网通讯接口、制动整流模块等模块化组合与集成，可满足物料搬运设备、印刷设备、包装设备、纺织设备等不同行业的应用；业界领先的速度响应性能、出色的定位精度、丰富的通讯接口，可满足客户对设备快速动态响应和精确位置控制的需求，并可根据客户需要进行个性化的设计与制造。

杰牌为全球好客户做好产品，杰牌智能传动方案提供商！

JIE'S JDC servo motor with independent intellectual property rights, is featured with beautiful appearance, low noise, high power density, low cogging torque and fast delivery, which is intelligent and trouble-free. It includes JDC..L low inertia and JDC..M middle inertia motor.

JDC servo motor promotes lean production, builds intelligent factories, and realizes the integration of research, production, supply, marketing and service, so as to meet customers' demand for rapid response through complete product planning and design such as "core product-extreme technology, peripheral product-extreme service, external product-extreme experience" and the implementation of the optimal plan of lean production in the whole value chain such as "product planning, design validation, processing test, assembly test, warehouse logistics, sales service, information system, HR, operation plan, strategy planning".

JDC servo motor follows the concept of modular and optimized design. Including plain shaft and shaft with key options. With incremental encoder and absolute encoder can fulfill customers quick response and high accuracy requirements. The motor also available for customize to fulfill customer's machine application.

JIE is committed to providing great products for great partners across the world. JIE Intelligent Drive Solutions Provider.

2. 电机型号描述 Servo Motor Model Description

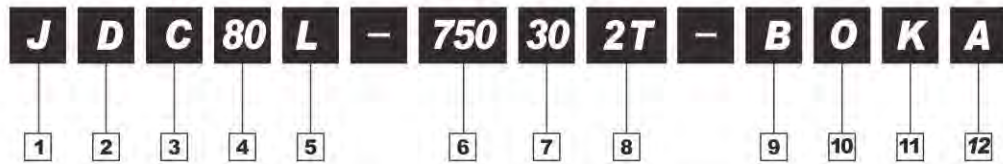

1	2	3	4	5
企业代码	产品代码	电机类型	法兰尺寸	惯量类型
J- 杰牌传动	D-电动机	C-伺服	60-60 x 60mm 80-80 x 80mm 130-130 x 130mm 180-180 x 180mm 200-200 x 200mm 263- 263 x263mm	L- 低惯量 M- 中惯量 H - 高惯量
6	7	8	9	
额定功率	额定转速	额定电压等级及编码器类型	抱闸	
400-400W ... 1K0-1.0kW 1K5-1.5kW ... 22K-22kW	15-1500r/min 20-2000r/min 30-3000r/min	2T -电压等级220V, 带2500ppr型编码器 2H-电压等级220V, 带17位单圈绝对值型编码器 2M -电压等级220V, 带23位多圈绝对值型编码器 4T -电压等级380V, 带2500ppr型编码器 4H-电压等级380V, 带17位单圈绝对值型编码器 4M -电压等级380V, 带23位多圈绝对值型编码器	A-不带抱闸 B-带抱闸	
10	11	12		
油封	输出轴方式	其它		
O-带油封 X-不带油封	S-光轴 K-带键轴 (所有电机输出轴都带中心螺纹孔)	A-仅限JIE内部使用		

注: 1.所有电机标配油封和带键轴。
2.详细订货信息请参考本手册第41页内容。

1	2	3	4	5
Enterprise code	Product code	Motor type	Frame Size	Inertia Type
J-JIE Drive	D-Motor	C-Servo	80-80×80 mm 100-100×100 mm 130-130×130 mm 180-180×180 mm	L-Low inertia M-Middle inertia H -High inertia
6	7	8	9	
Rated Power	Rated Speed	Voltage Grade and Encoder Type	Brake	
750-750W 1K0-1.0kW 1K5-1.5kW ... 7K0-7.0kW	20-2000r/min 30-3000r/min	2T -Voltage 220V + Incremental Encoder 2H-Voltage 220V + 17bit Absolute Encoder 2M -Voltage 220V + 23bit Absolute Encoder 4T -Voltage 380V + Incremental Encoder 4H-Voltage 380V + 17bit Absolute Encoder 4M -Voltage 380V + 23bit Absolute Encoder	A-Without brake B-With brake	
10	11	12		
Oil Seal	Shaft End	Other		
O-With X-Without	S-Plain shaft K-With key shaft (All shaft end with center screw hole)	A-Only for JIE use		

Note: 1.All motor with oil seal and key shaft.
2.For more order information please refer to Page 41.

3. 驱动器型号描述 Servo Drive Model Description



1	2	3	4	5
企业代码	产品代码	驱动器类型	产品系列	额定功率
J- 杰牌传动	C-驱动器	S-伺服	500-系列名称	OK4- 400W OK7-750W 1K0-1.0kW ... 022-22kW
6	7	8	9	10
电源电压	驱动器版本类型	编码器类型	产品管理号	客制化产品
2V-220V 4V-380V	E-脉冲型 N-EtherCAT总线型 PN-Profinet S-标准型(仅限 7.5kW及以上功率规格)	0-光电编码器	A1-硬件版本	S-标准款 01-客户代码

注：详细订货信息请参考本手册第42页内容。

1	2	3	4	5
Enterprise code	Product code	Drive type	Series	Rated power
J-JIE Drive	C-Drive	S-Servo	500-Product Series	OK4- 400W OK7-750W 1K0-1.0kW ... 022-22kW
6	7	8	9	10
Supply Voltage	Drive version	Encoder type	Hardware	Customize
2V-220V 4V-380V	E-Plus train N-EtherCAT PN-Profinet S - Stanadard (Only for 7.5kW and above power)	0-Optical encoder	A1-Hardware version	S - Standard 01 - Customer code ...

Note: For more order information please refer to Page 42.

四. 产品结构 Product Structure

1. JDC 伺服电机 JDC Servo Motor

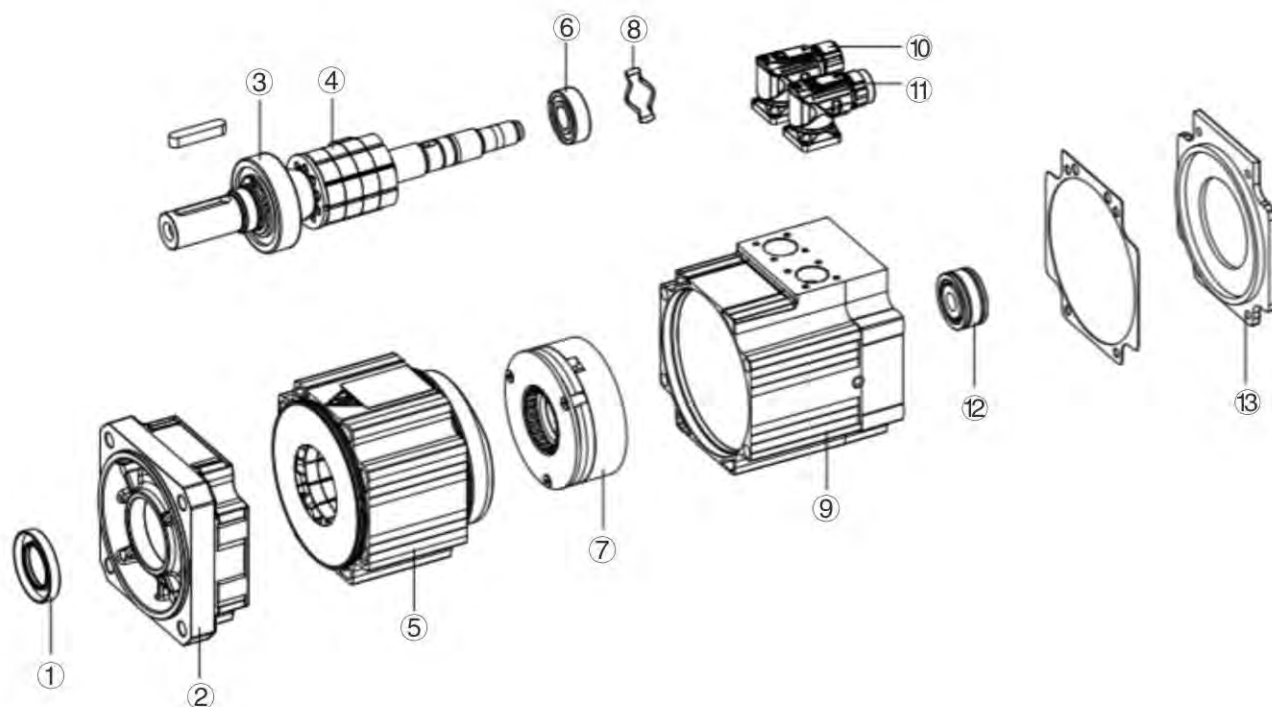

- | | |
|------------------------------|------------------------------------|
| 1.油封/Oil seal | 8.垫片/Washer |
| 2.法兰/Flange | 9.抱闸端盖/Holdingbrakeshielding |
| 3.前端轴承/Front end bearing | 10.编码器连接器/Encoderconnector |
| 4.转子/Rotor | 11.电源及抱闸连接器/Powerandbrakeconnector |
| 5.定子(带机壳)/Stator(With shell) | 12.编码器/Encoder |
| 6.后端轴承/Back end bearing | 13.后端盖/Backendshield |
| 7.抱闸/Holding brake | |

五. 选型说明

Selection Description

杰牌传动JDC和JCS产品选型表

使用工况:	
应用行业:	设备名称:
环境温度:	环境湿度:
海拔高度:	使用场地: <input type="checkbox"/> 室内 <input type="checkbox"/> 室外
起停频率:	运行时间:
负载时间: <input type="checkbox"/> 15% <input type="checkbox"/> 25% <input type="checkbox"/> 40% <input type="checkbox"/> 60% <input type="checkbox"/> 100%	
现用品牌:	现用型号:
存在问题:	需改进项:

JDC产品信息:	
包装附件类: 包装材质: <input type="checkbox"/> 纸箱 <input type="checkbox"/> 木箱	箱贴唛头: <input type="checkbox"/> 中文 <input type="checkbox"/> 英文
相关资料: <input type="checkbox"/> 合格证 <input type="checkbox"/> 出厂检验报告 <input type="checkbox"/> 中文使用说明书 <input type="checkbox"/> 英文使用说明书	
附件清单: <input type="checkbox"/> 带增量型编码器 <input type="checkbox"/> 带绝对型编码器 <input type="checkbox"/> 带保持制动器	
<input type="checkbox"/> 3米电源电缆	<input type="checkbox"/> 3米编码器电缆
<input type="checkbox"/> 5米电源电缆	<input type="checkbox"/> 5米编码器电缆
<input type="checkbox"/> 15米电源电缆	<input type="checkbox"/> 15米编码器电缆
外观标识类:	
油漆颜色: <input type="checkbox"/> JMR-01 <input type="checkbox"/> RAL9005	铭牌要求: <input type="checkbox"/> 中文 <input type="checkbox"/> 英文
防腐要求: <input type="checkbox"/> 标准 <input type="checkbox"/> JS1 <input type="checkbox"/> JS2 <input type="checkbox"/> JS3 <input type="checkbox"/> JS4	电机法兰: <input type="checkbox"/> 60 <input type="checkbox"/> 80 <input type="checkbox"/> 130 <input type="checkbox"/> 180 mm
安装形式: <input type="checkbox"/> B5	性能指标类: 额定功率: kW
额定转速: <input type="checkbox"/> 2000r/min <input type="checkbox"/> 3000r/min 额定电压: <input type="checkbox"/> 220V <input type="checkbox"/> 380V	
防护等级: <input type="checkbox"/> IP65 工作制: <input type="checkbox"/> S1 <input type="checkbox"/> S3-40%	
旋转方向: <input type="checkbox"/> 顺时针 <input type="checkbox"/> 逆时针	
完整产品型号: _____	
JCS产品信息:	
包装附件类: 包装材质: <input type="checkbox"/> 纸箱 <input type="checkbox"/> 木箱	箱贴唛头: <input type="checkbox"/> 中文 <input type="checkbox"/> 英文
相关资料: <input type="checkbox"/> 合格证 <input type="checkbox"/> 出厂检验报告 <input type="checkbox"/> 中文使用说明书 <input type="checkbox"/> 英文使用说明书	
电压等级: <input type="checkbox"/> 220V <input type="checkbox"/> 400V	额定功率: kW
通讯方式: <input type="checkbox"/> 脉冲型 <input type="checkbox"/> EtherCAT <input type="checkbox"/> Profinet	

2. JCS 伺服驱动器 JCS Servo Drive

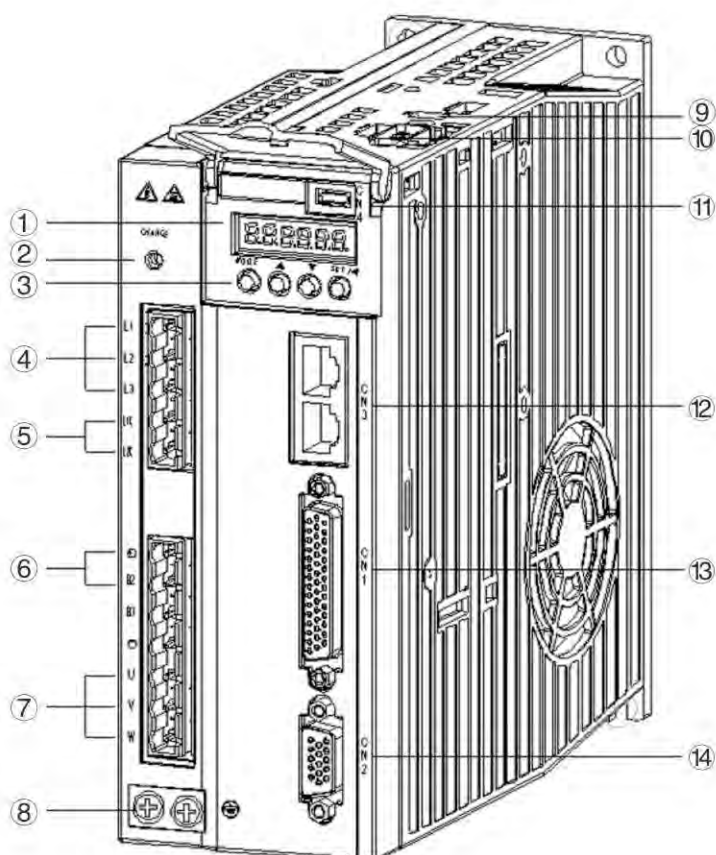

- | | |
|----------------------------------|---|
| 1. 数码显示屏/LED display | 2. CHARGE灯/CHARGE light |
| 3. 操作面板/Operating buttons | 4. 主回路电源/Supply line power |
| 5. 控制回路电源/Control power | 6. 再生电阻/ |
| 7. 电机动力连接/Motor power connector | 8. 接地/ |
| 9. S1开关:STO选择/ | 10. CN5接口:第二编码器及STO/CN5 for second encoder use |
| 11. CN4接口:上位机USB接口/USB interface | 12. CN3接口:CAN/RS485通讯/CAN and RS485 communication |
| 13. CN1接口:I/O控制/I/O interface | 14. CN2接口:电机编码器连接/CN2 for motor encoder connector |

定制信息：

包装附件类：

外观标识类：

安装尺寸类：

性能指标类：

售后服务类：

服务信息：

售前服务：

培训咨询：选型培训 应用培训 使用维护

设计选型：参与设计 设计校核 产品选型

需求确认：工况确认 产品确认 服务确认

售中服务：驻厂全检 过程抽检 出厂检验

售后服务：安装调试 检测维护 备品备件

商务信息：

运输方式：

交付地点：

交付时间：

订单数量：

结算价格：

附图：

Selection Table of JIE JDC Products

Conditions of Use:	
Application industry:	Equipment name:
Ambient temperature:	Ambient humidity:
Altitude:	Site of use: <input type="checkbox"/> indoor <input type="checkbox"/> outdoor
Start-stop frequency:	Running time:
Load time: <input type="checkbox"/> 15% <input type="checkbox"/> 25% <input type="checkbox"/> 40% <input type="checkbox"/> 60% <input type="checkbox"/> 100%	
Current brand:	Current model:
Existing problem:	Items needing improvement:

Brake cable:
Product information:
Packaging:
Packaging material: <input type="checkbox"/> Carton <input type="checkbox"/> Wooden case <input type="checkbox"/> Carton + Wooden case Case mark: <input type="checkbox"/> Chinese <input type="checkbox"/> English
Relevant data: <input type="checkbox"/> Certificate of conformity <input type="checkbox"/> Ex-factory inspection report <input type="checkbox"/> Chinese operating instruction <input type="checkbox"/> English operating instruction
List of accessories: <input type="checkbox"/> Incremental encoder <input type="checkbox"/> Absolute encoder <input type="checkbox"/> Holding brake <input type="checkbox"/> 3m Power cable <input type="checkbox"/> 5m Power cable <input type="checkbox"/> 15m Power cable <input type="checkbox"/> 3m Brake cable <input type="checkbox"/> 5m Brake cable <input type="checkbox"/> 15m Brake cable <input type="checkbox"/> 3m Encoder cable <input type="checkbox"/> 5m Encoder cable <input type="checkbox"/> 15m Encoder cable
Appearance:
Paint color: <input type="checkbox"/> JMR-01 <input type="checkbox"/> RAL9005
Nameplate requirement: <input type="checkbox"/> Chinese <input type="checkbox"/> English
Anti-corrosive grade: <input type="checkbox"/> Standard <input type="checkbox"/> JS1 <input type="checkbox"/> JS2 <input type="checkbox"/> JS3 <input type="checkbox"/> JS4
Installation:
Motor shaft height: <input type="checkbox"/> SH30 <input type="checkbox"/> SH40 <input type="checkbox"/> SH65 <input type="checkbox"/> SH90 mm
Type of installation: <input type="checkbox"/> B5 Performance: Rated power: kW
Rated speed: <input type="checkbox"/> 2000r/min <input type="checkbox"/> 3000r/min Rated voltage: <input type="checkbox"/> 220V <input type="checkbox"/> 380V
Protection grade: <input type="checkbox"/> IP65 Working system: <input type="checkbox"/> S1 <input type="checkbox"/> S3-40%
Product model:

Customized information: Packing category: Appearance class: Installation dimension: Performance indicators: After-sales service:
Service information: Pre-sales service: Training consulting: <input type="checkbox"/> Type selection training <input type="checkbox"/> Application training <input type="checkbox"/> Use and maintenance Design selection: <input type="checkbox"/> Participate in design <input type="checkbox"/> Design verification <input type="checkbox"/> Product selection Demand confirmation: <input type="checkbox"/> Working condition confirmation <input type="checkbox"/> Product confirmation <input type="checkbox"/> Service confirmation In-sales service: <input type="checkbox"/> On-site full inspection <input type="checkbox"/> Process sampling <input type="checkbox"/> Ex-factory inspection After-sales service: <input type="checkbox"/> Installation and commissioning <input type="checkbox"/> Testing and maintenance <input type="checkbox"/> Spare parts
Business information: Transportation: Delivery place: Delivery time: Order quantity: Settlement price:
Attached figure:

六. 电机技术参数 Servo Motor Technical Data

1. 电气参数 Electrical Technical Data

额定电压等级220V伺服电机/220V Servo Motor

型号 Model	JDC60L	JDC80L	JDC130M		JDC60L	JDC80L	JDC130M
法兰规格 Flange Size	60X60mm	80X80mm	130X130mm		60X60mm	80X80mm	130X130mm
额定功率(kW) Rated Power	0.4	0.75	1.0	1.5	0.4	0.75	1.0
额定扭矩(Nm) Rated Torque	1.27	2.39	4.78	7.16	1.27	2.39	4.78
额定速度(r/min) Rated Speed	3000		2000		3000		2000
最大扭矩(Nm) Max. Torque	3.9	7.2	14.3	21.4	3.81	7.5	14.3
最大速度(r/min) Max. Speed	5000		3000		5000		2500
额定电流(A) Rated Current	2.8	4.5	4.8	7.6	2.3	4.3	4.72
最大电流(A) Max. Current	8.4	13.5	14.4	22.8	6.9	12.9	14.2
扭矩常数(Nm/A) Torque Constant	0.45	0.53	1.00	0.94	0.55	0.56	1.01
惯量(10^{-4} kg·m ²)(带抱闸) Rotor Inertia(With Brake)	0.29 (0.33)	1.28 (1.51)	6.4 (8.3)	9.3 (11.2)	0.3 (0.302)	1.015 (1.018)	8.71 (8.72)
热绝缘等级 Thermal Class	F级(155°C)						
防护等级 Protection level	IP 65						
推荐负载惯量与电机的惯量比 Recommended load to motor inertia ratio	最大20倍 Max.20times		最大10倍 Max.10times		最大20倍 Max.20times		最大10倍 Max.10times
编码器类型 Encoder Types	可选: 增量型 TTL2500ppr 或; 23位多圈绝对值型				带17位单圈绝对值型 With 17bit Single Turn Absolute		
安装类型 Assembling	IM B5 (IM V1 和 IM V3)						
运行温度 Ambient Temp.	0 ~ 40°C (无任何限制)						
运行湿度 Humidity	最大90% RH (30°C时无凝露)						
振动等级 Vibration	A级						
径向抖动公差 Shaft and flange accuracy	N级						
安装海拔高度 Installation Altitude	低于1000m(不降容), 1000~5000m范围内(需降容使用)						
重量,约(kg),(带抱闸) Weight (kg),(With brake)	1.6 (2.1)	3.0 (3.5)	5.8 (7.5)	7.1 (8.8)	1.37 (1.78)	2.5 (3.4)	6.41 (7.94)
抱闸规格 Holding Brake							
抱闸扭矩(Nm) Holding Torque	1.3	2.4	4.8	7.2	无带抱闸选项		
额定电压(V) Rated Voltage	DC 24V±10%						
抱闸打开时间(ms) Open Time	20	20	40				
抱闸关闭时间(ms) Closing Time	50	70	80				
额定运行电流(A) Rated Current	0.3	0.4	0.96				

额定电压等级380V伺服电机/380V Servo Motor

型号 Model	JDC130M			JDC180M			
法兰规格 Flange Size	130X130mm			180X180mm			
额定功率(kW) Rated Power	1.0	1.5	2.0	3.0	4.4	5.5	7.5
额定扭矩(Nm) Rated Torque	4.78	7.16	9.55	19	27	35	48
额定速度(r/min) Rated Speed	2000			1500			
最大扭矩(Nm) Max. Torque	14.3	21.4	28.6	47	67	70	96
最大速度(r/min) Max. Speed	3000			2000			
额定电流(A) Rated Current	2.8	4.5	5.5	7.5	10	12	20
最大电流(A) Max. Current	8.4	13.5	16.5	18.7	25	24	40
扭矩常数(Nm/A) Torque Constant	1.71	1.59	1.74	2.53	2.70	2.92	2.40
惯量($10^4 \text{kg} \cdot \text{m}^2$)(带抱闸) Rotor Inertia(With Brake)	6.4 (8.3)	9.3 (11.2)	12.2 (14.1)	70 (74)	97 (101)	86 (127)	168 (179)
热绝缘等级 Thermal Class	F级(155°C)						
防护等级 Protection level	IP 65						
推荐负载惯量与电机的惯量比 Recommended load to motor inertia ratio	最大10倍 Max. 10times			最大5倍 Max. 5times			
编码器类型 Encoder Types	可选: 增量型 TTL2500ppr 或; 21位多圈绝对值 Options: Incremental TTL 2500 S/R Or Absolute 21bits						
安装类型 Assembling	IM B5 (IM V1 和 IM V3) IM B5 (IM V1 Or IM V3)						
运行温度 Ambient Temp.	0 ~ 40°C (无任何限制) 0 ~ 40°C (Without restrict)						
运行湿度 Humidity	最大90% RH (30°C时无凝露) 90% RH at 30°C (No condensation)						
振动等级 Vibration	A级 Grade A						
径向抖动公差 Shaft and flange accuracy	N级 Tolerance N						
安装海拔高度 Installation Altitude	低于1000m(不降容), 1000~5000m范围内(需降容使用) Up to 1000m above sea level without derating > 1000~5000m with derating						
重量,约(kg),(带抱闸) Weight (kg),(With brake)	1.6 (2.1)	3.0 (3.5)	5.8 (7.5)	7.1 (8.8)	1.37 (1.78)	2.5 (3.4)	6.41 (7.94)
抱闸规格 Holding Brake							
抱闸扭矩(Nm) Holding Torque	4.8	7.2	9.6	19	27	35	48
额定电压(V) Rated Voltage	DC 24V \pm 10%						
抱闸打开时间(ms) Open Time	40			180			
抱闸关闭时间(ms) Closing Time	80			80			
额定运行电流(A) Rated Current	0.96			1.25			

2. 扭矩-速度曲线 Torque-Speed Curve

额定电压等级220V伺服电机/220V Servo Motor

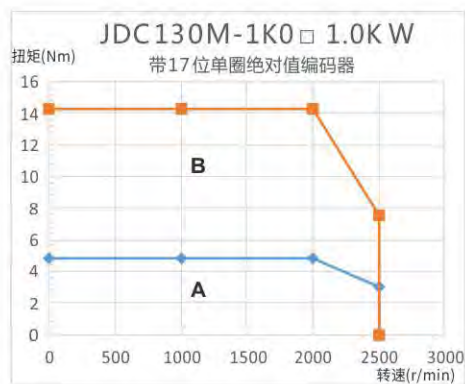
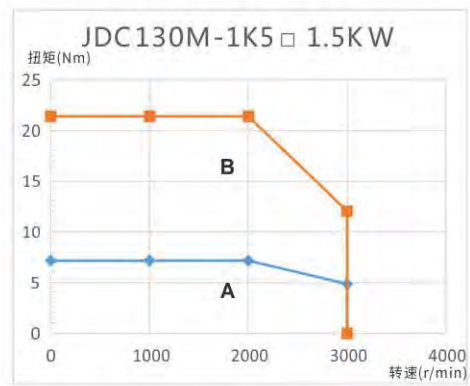
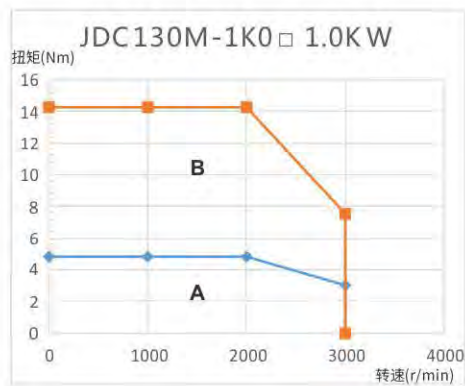
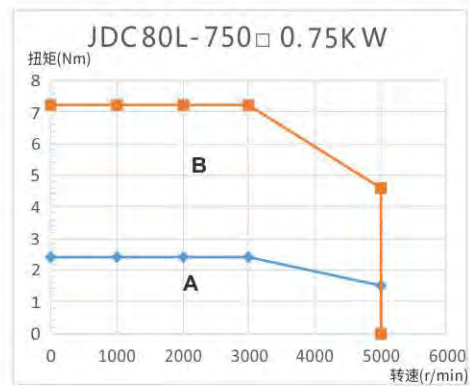
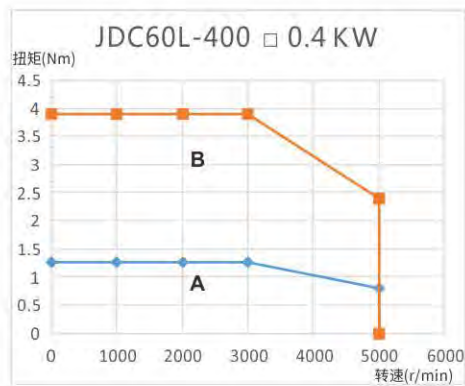

说明

A: 连续工作区

B: 间歇工作区

Note

A: Continuous work area

B: Intermittent work area

额定电压等级380V伺服电机/380V Servo Motor

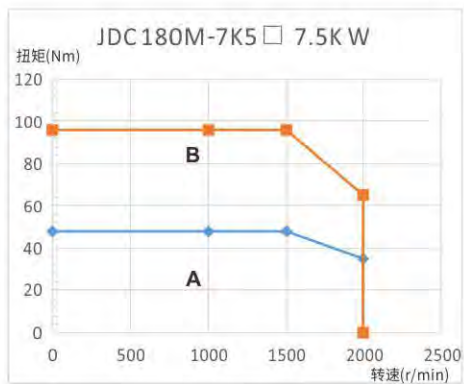
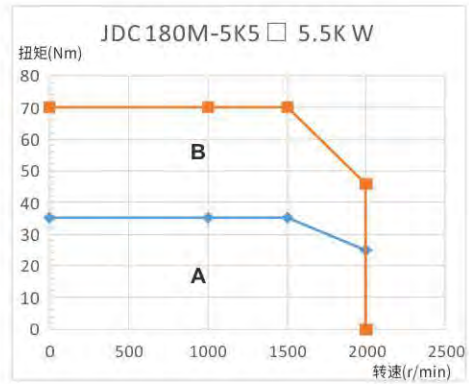
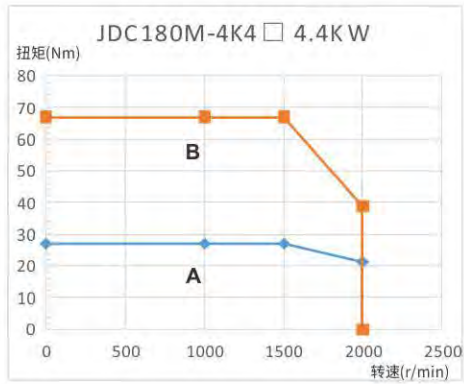
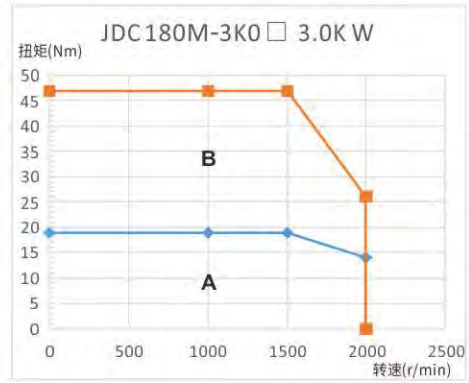
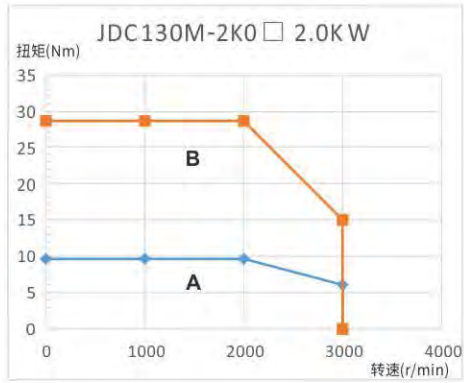
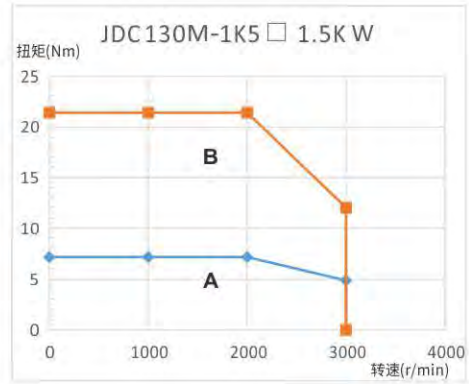
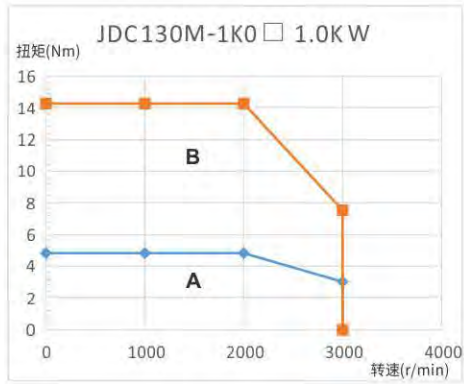

说明
A: 连续工作区
B: 间歇工作区

Note
A: Continuous work area
B: Intermittent work area

3. 电机尺寸 Motor Dimension

60法兰外形图及安装尺寸/Flange Size 60 (mm)

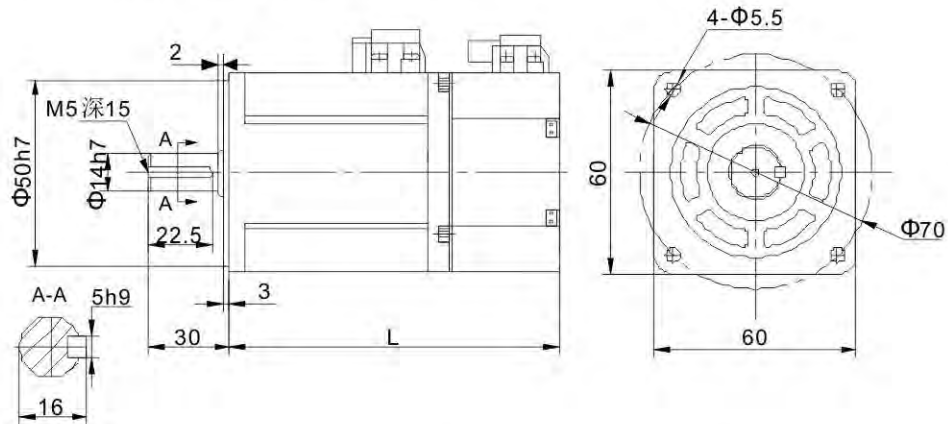

电机型号(2500线/23位多圈绝对值编码器) Type (With 2500ppr or 23bit absolute encoder)	L(mm)	
	无抱闸/Without brake	带抱闸/With brake
JDC60L-400302□-□OKA	141	189

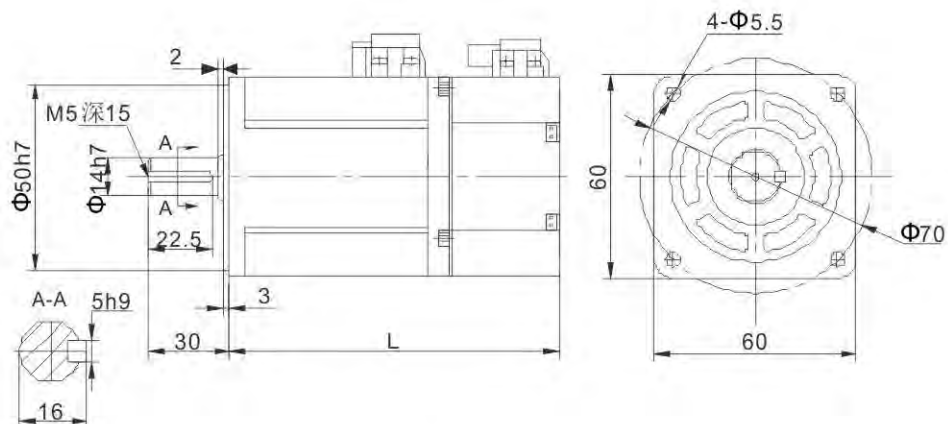

电机型号(17位单圈绝对值编码器) Type (With 17bit absolute encoder)	L(mm)	
	无抱闸/Without brake	带抱闸/With brake
JDC60L-400302H-AOKA	133	无该选项电机/No

80法兰外形图及安装尺寸/Flange Size 80 (mm)

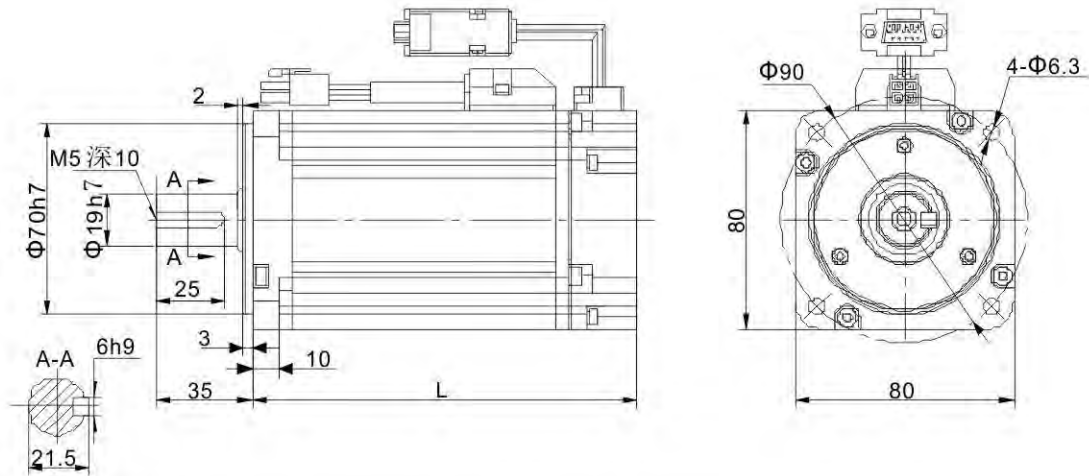

电机型号(2500线/23位多圈绝对值编码器) Type (With 2500ppr or 23bit absolute encoder)	L(mm)	
	无抱闸/Without brake	带抱闸/With brake
JDC80L-750302□-□OKA	140	无该选项电机/No

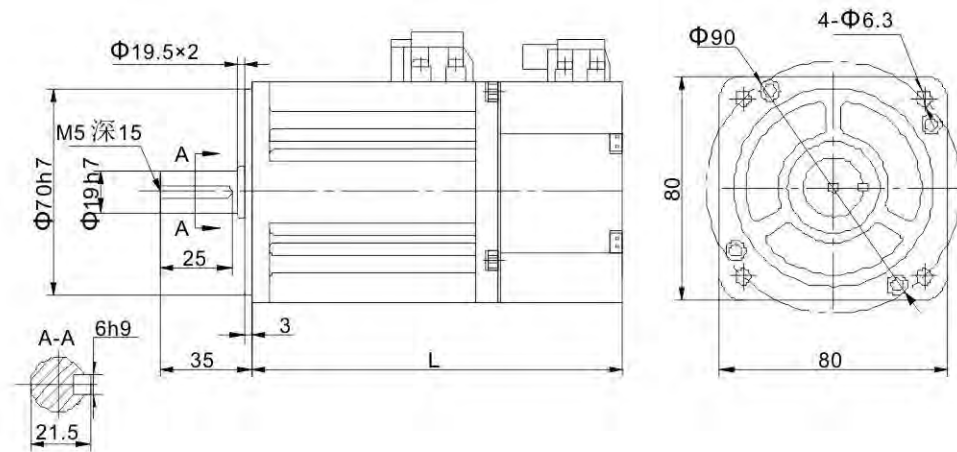

电机型号(17位单圈绝对值编码器) Type (With 17bit absolute encoder)	L(mm)	
	无抱闸/Without brake	带抱闸/With brake
JDC80L-750302H-AOKA	141	无该选项电机/No

180法兰外形图及安装尺寸/Flange Size 180 (mm)

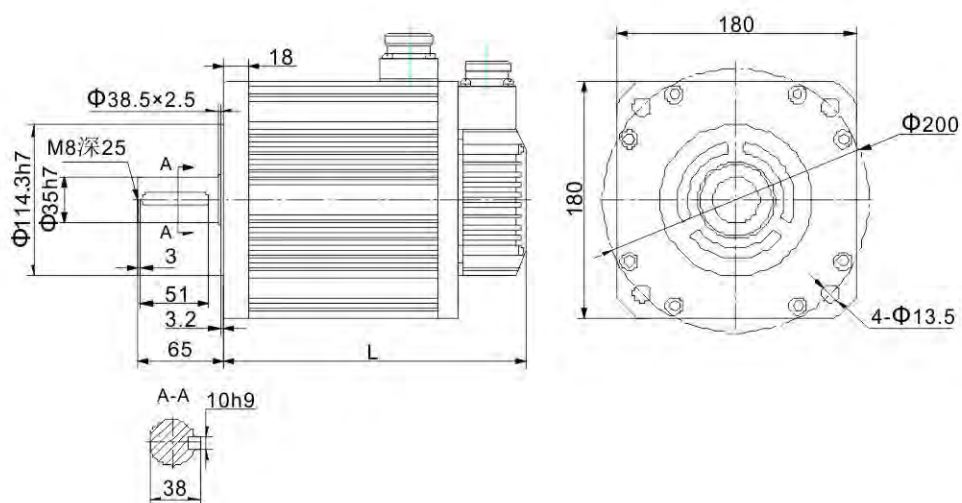

电机型号(2500线/23位多圈绝对值编码器) Type (With 2500ppr or 23bit absolute encoder)	L(mm)	
	无抱闸/Without brake	带抱闸/With brake
JDC180M-3K0154□-□OKA	232	304
JDC180M-4K4154□-□OKA	262	334
JDC180M-5K5154□-□OKA	292	364
JDC180M-7K5154□-□OKA	346	418

七. 驱动器技术参数

Servo Drive Technical Data

1. 电气参数

Electrical Technical Data

基本参数 Basic Parameter

环境参数 Environment Data	
工作温度 Operating temperature	0~45°C
储存温度 Storage temperature	-20~80°C (不冻结)
工作/储存湿度 Working/storage humidity	≤90%RH (无凝露)
IP等级 Protecting grade	IP20
海拔限制 Altitude limitation	≤1000m
振动 Vibration	≤5.88m/s ² 10~60Hz (不允许工作在共振点)

保护功能 Protecting Function	
硬件保护 Hardware protection	过压、欠压、过流、过速、过载、制动电阻过载、驱动器过热、编码器故障等 Overvoltage, undervoltage, overcurrent, overspeed, overload, brake resistor overload, driver overheating, encoder failure, etc.
软件保护 Software protection	存储器故障、初始化故障、I/O分配异常、位置偏差过大等 Memory failure, initialization failure, abnormal I/O allocation, excessive position deviation, etc.
保护及故障记录 Protection and fault records	1、可记录10个故障 2、可记录当前故障发生时的关键参数值 1.10 faults can be recorded, 2.Key parameter values when current faults can be recorded

供电电源 Power Supply	
系统输入电压: 220V Input voltage 220V	1P/3P AC220V(-15%)~240V(+10%) 47Hz~63Hz
系统输入电压: 400V Input voltage 400V	3P AC380V(-15%)~440V(+10%) 47Hz~63Hz

端口描述 Interface Description

控制信号 端口 Control port	输入 Input	标准型、脉冲型及CANopen总线型为10路输入，EtherCAT总线型为7路输入，MotionNet总线型为5路输入(功能可通过相关参数配置) Standard type, pulse type and CANopen bus type have 10 inputs, EtherCAT bus type has 7 inputs, and MotionNet bus type has 5 inputs (functions can be configured by related parameters)
	输出 Output	标准型、脉冲型及CANopen总线型为6路单端输出，EtherCAT总线型为4路差分输出，MotionNet总线型为1路单端输出(功能可通过相关参数配置) Standard type, pulse type and CANopen bus type are 6 single-ended outputs, EtherCAT bus type is 4 differential outputs, and MotionNet bus type is 1 single-ended output (functions can be configured through related parameters)
模拟量 端口 Analog port	输入 Input	标准型3路输入(1路16bit、2路12bit模拟量输入)，非标准型2路输入(2路12bit模拟量输入) Standard 3 inputs (1 for 16bit, 2 for 12bit analog inputs), non-standard 2 inputs (2 for 12bit analog inputs)
	输出 Output	2路(模拟量输出) 2 (analog output)
脉冲信号 端口 Pulse port	输入 Input	1组(方式：差分输入或者集电极开路输入) 1 group (mode: differential input or open collector input)
	输出 Output	1组[方式：差分输出(A+/A-、B+/B-、Z+/Z-)或者集电极开路输出(A、B、Z)] 1 group [Method: Differential output (A + / A-, B + / B-, Z + / Z-) or open collector output (A, B, Z)]
第二编码器端口 Second encoder port	输入 Input	增量编码器接口(第二编码器或光栅尺) Incremental encoder interface (second encoder or scale)
通信功能 端口 Communication port	USB	1:1 通信上位机软件(标配) 1:1 Communication PC software (Standard)
	RS485	1:n 通信(标配) 1:n Communication (Standard)
	CANopen	1:n 通信(选配) 1:n Communication (Optional)
	Profibus-DP	1:n 通信(选配) 1:n Communication (Optional)
	EtherCAT	1:n 通信(选配) 1:n Communication (Optional)
安全端子 Safety terminal	STO	Safe torque off 符合最新欧洲安全标准 (选配) Conforms to the latest European safety standards (Optional)

2. 控制模式 Control Models

控制描述 Control Description

控制模式 Control models	说明 Description
控制模式 Models	1、位置控制；2、速度控制；3、转矩控制；4、位置/速度模式切换； 5、速度/转矩模式切换；6、位置/转矩模式切换；7、全闭环控制； 8、CANopen模式；9、EtherCAT模式；10、MotionNet模式 1. Position control; 2. Speed control; 3. Torque control; 4. Position / speed mode switching; 5. Speed / torque mode switching; 6. Position / torque mode switching; 7. Full closed-loop control; 8. CANopen mode; 9. EtherCAT mode; 10. MotionNet mode

内部位置规划 Internal positioning

控制模式 Control models	说明 Description
规划点数 Planning points	可进行128点内部位置规划设定，可通信控制定位 128-point internal position planning and setting, communication control positioning
路径设定 Path setting	1、位置；2、速度；3、加速时间；4、减速时间；5、停止定时器；6、各种状态输出；7、运行模式 1. Position; 2. Speed; 3. Acceleration time; 4. Deceleration time; 5. Stop timer; 6. Various status outputs; 7. Operating mode.
原点回归 Origin return	1、LS信号；2、Z相信号；3、LS信号+Z相信号；4、力矩限制信号 1. LS signal; 2. Z-phase signal; 3. LS signal + Z-phase signal; 4. Torque limit signal.

位置控制 Position Control

控制模式 Control models	说明 Description	
控制输入 Input	1、滞留脉冲清零；2、指令脉冲输入禁止；3、电子齿轮比切换；4、制振控制切换等 1. Residual pulse clearing; 2. Command pulse input is prohibited; 3. Electronic gear ratio switching; 4. Vibration control switching, etc.	
控制输出 Output	定位完成输出等 Positioning completion output, etc.	
脉冲输入 Pulse input	最大脉冲输入频率 Maximum pulse input frequency	光电耦合：差分输入4Mpps，集电极开路输入200kpps Photoelectric coupling: differential input 4Mpps, open collector input 200kpps
	脉冲输入方式 Pulse input method	1、脉冲+方向；2、CW+CCW；3、正交编码 1. Pulse + direction; 2. CW + CCW; 3. Orthogonal coding
	电子齿轮 Electronic gear	1/10000~1000倍 1/10000~1000 times
	滤波器 Filter	1、指令平滑滤波器；2、FIR滤波器 1. Instruction smoothing filter; 2. FIR filter
模拟量输入 Analog input	转矩限制指令输入 Torque limit command input	可单独进行顺/逆时针方向的转矩限制 Independent clockwise/counterclockwise torque limit
抑振控制 Damping control	能抑制5~200Hz的前端振动及整机振动 Can suppress 5 ~ 200Hz front-end vibration and machine vibration	
脉冲输出 Pulse output	1、可进行编码器分辨率以下的任意分频设定 2、具有B相取反功能 1. Can set any frequency division below the encoder resolution 2. With phase B inversion function	

速度控制 Speed Control

控制模式 Control models	说明 Description	
控制输入 Input	1、内部指令速度选择1； 2、内部指令速度选择2； 3、内部指令速度选择3； 4、零速钳位等 1. Internal command speed selection 1; 2. internal command speed selection 2; 3. internal command speed selection 3; 4. zero speed clamping, etc.	
控制输出 Output	速度到达等 Speed arrival etc.	
模拟量输入 Analog input	速度指令输入 Speed command input	可根据模拟量电压DC±10V进行相关设定后为速度指令输入 Speed command input can be set according to the analog voltage DC±10V
	转矩限制输入 Torque limit input	可单独进行顺/逆时针方向的转矩限制 Independent clockwise / counterclockwise torque limit
内部速度指令 Internal speed command	可根据外部控制输入进行切换内部8段速度 8 internal speeds can be switched according to external control input	
速度指令加减速调整 Speed command acceleration / deceleration adjustment	可单独设定加减速时间，也可进行S曲线加减速设定 Acceleration / deceleration time can be set independently, and S-curve acceleration / deceleration settings can also be set	
零速钳位 Zerospeed clamp	零速钳位功能在速度模式下，可设定工作在速度模式或位置模式 Zero speed clamp function can be set to work in speed mode or position mode in speed mode	
速度指令滤波器 Speed command filter	模拟量输入速度指令的一次延时滤波器 One-time delay filter for analog input speed command	
速度指令零漂抑制 Speed command zero drift suppression	能对外围干扰等进行零漂抑制，精度0.3mV Speed command zero drift suppression	

转矩控制 Torque Control

控制模式 Control models	说明 Description	
控制输入 Input	零速钳位输入等 Zero speed clamp input, etc.	
控制输出 Output	速度到达等 Speed arrival	
模拟量输入 Analog input	转矩指令输入 Torque command input	模拟量转矩指令输入，可根据模拟量电压进行增益和极性设定，精度4.88mV Analog torque command input, gain and polarity can be set according to analog voltage, precision 4.88mV
	速度限制输入 Speed limit input	可进行模拟量速度限制 Analog speed limitation possible
速度限制 Speed limit	通过参数可设定速度限制 Speed limit can be set by parameters	
转矩指令滤波器 Torque command filter	模拟量输入转矩指令的一次延时滤波器 Primary delay filter for analog input torque command	
转矩指令零漂抑制 Torque command zero drift suppression	能对外围干扰等进行零漂抑制，精度4.88mV Zero-drift suppression for peripheral interference, etc., precision 4.88mV	

3. 驱动器安装尺寸 Drive Installation Dimension

A/B/C 规格体积尺寸 Frame Size A/B/C Dimension

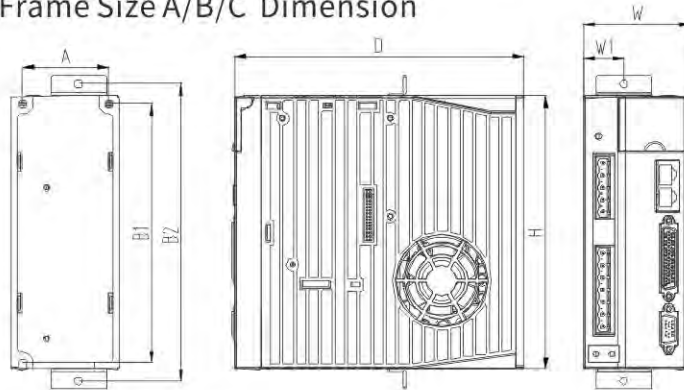

D 规格体积尺寸 Frame Size D Dimension

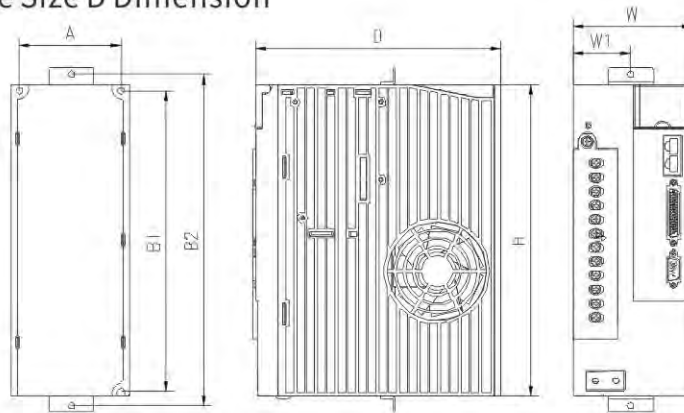

F 规格体积尺寸 Frame Size F Dimension

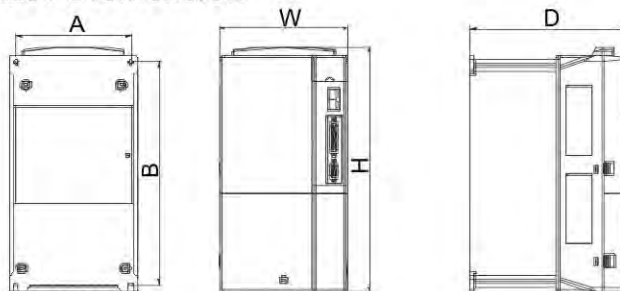

规格 体积 Size	型号 Type	外形尺寸 Outlet			安装尺寸 Installation				
		H (mm)	W (mm)	D (mm)	A (mm)	B1 (mm)	B2 (mm)	W1 (mm)	安装孔径(mm) Mounting hole
A	JCS500-0K4-2V	170	45	170	33	162	185	22.5	M4(Φ5)
B	JCS500-0K7-2V	170	67	180	54	162	185	25	M4(Φ5)
	JCS500-1K0-2V								
	JCS500-1K5-2V								
	JCS500-1K0-4V								
	JCS500-1K5-4V								
C	JCS500-2K0-4V	170	84	180	71	162	185	42	M4(Φ5)
	JCS500-3K0-4V								
D	JCS500-4K4-4V	245	92	190	79	237	260	45	M4(Φ5)
	JCS500-5K5-4V								
F	JCS500-7K5-4V	342	230	208	210	311	/	/	M5(Φ6)

4. 驱动器安装要求 Drive Installation Standard

单台安装 For Single Drive Installation

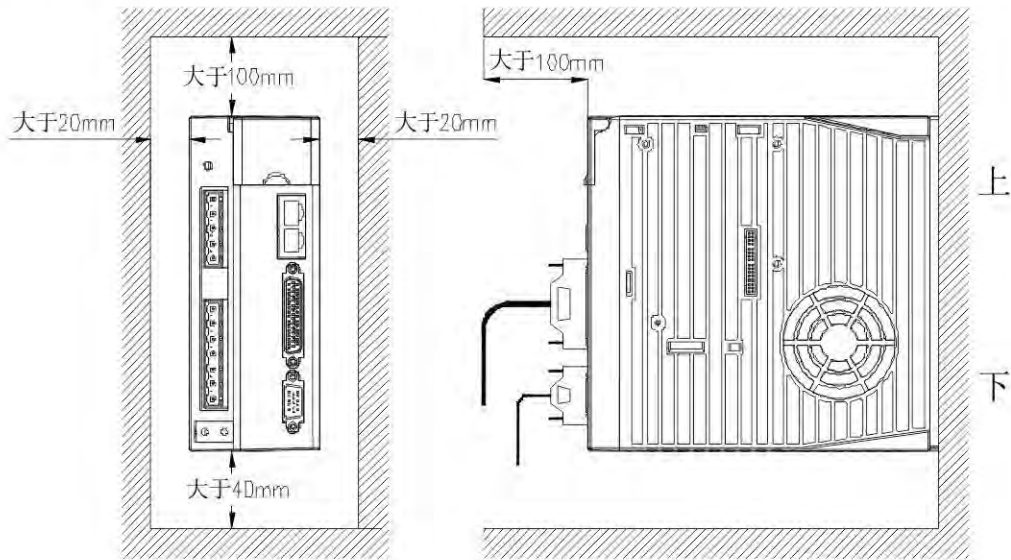

多台安装 For Multiple Drive Installation

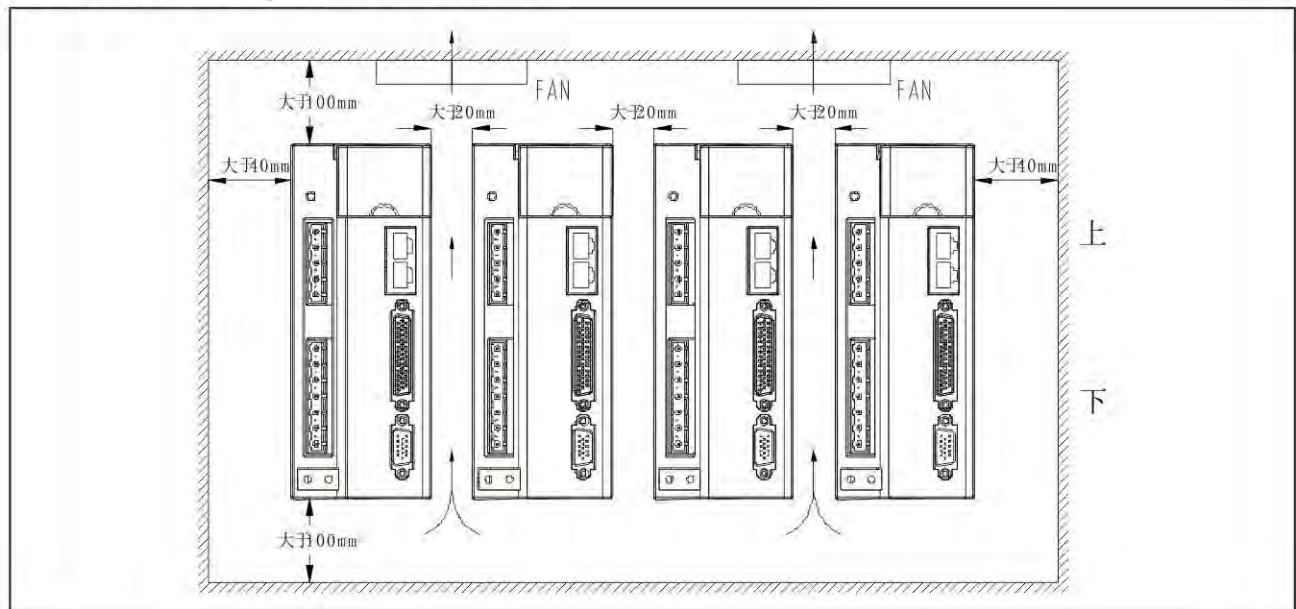

注:

- 请竖直安装伺服驱动器，并在其周围保留足够的空间以便于通风；
- 必要时请安装风扇，使控制柜内温度低于45°C。

Note:

- Please install the servo drive vertically and leave enough space around it for ventilation;
- If necessary please install the fan to ensure the temperature of control cabinet is lower than 45 °C.

八. 系统配置 System Constructure

1. 系统配线 System Structure

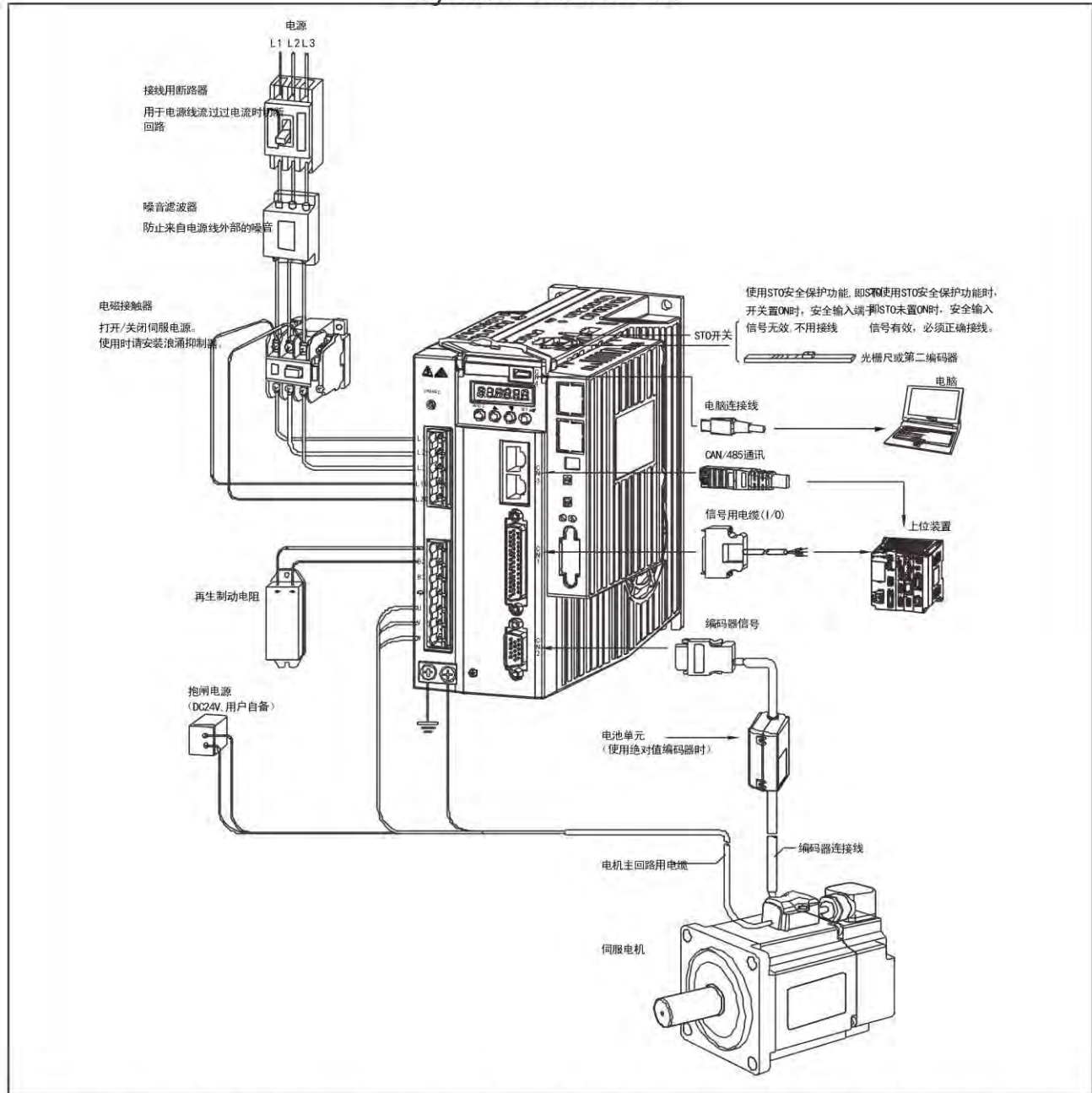

注：①请务必确认电网电源与机器铭牌标示的输入电源规格相一致后才可接通驱动器输入电源；②电磁接触器用来接通与断开伺服驱动器的主回路电源，不要用它来启停伺服驱动器；③上图中接的是外部再生制动电阻，此时B2、B3间的短接线要拆除，具体接法请参见使用说明书；④外部再生制动电阻一定要安装在阻燃性且散热性能良好的物质上，如金属。

Note: ①Please make sure that the power supply of the power grid is consistent with the input power specification indicated on the nameplate of the machine before connecting the input power of the driver. ②The electromagnetic contactor is used to connect and disconnect the main circuit power supply of the servo driver. Do not use it to start and stop the servo driver. ③The external regenerative braking resistor is connected in the figure above. At this time, the short circuit between B2 and B3 should be removed. Please refer to the operation manual for the specific connection method. ④The external regenerative braking resistor must be installed on the material with good flame retardancy and heat dissipation performance, such as metal.

2. 控制模式接线图 Control Model Connection

位置模式接线图(适用于脉冲输入控制)
Positioning Control Connection(Suit for Pulse Input Control)

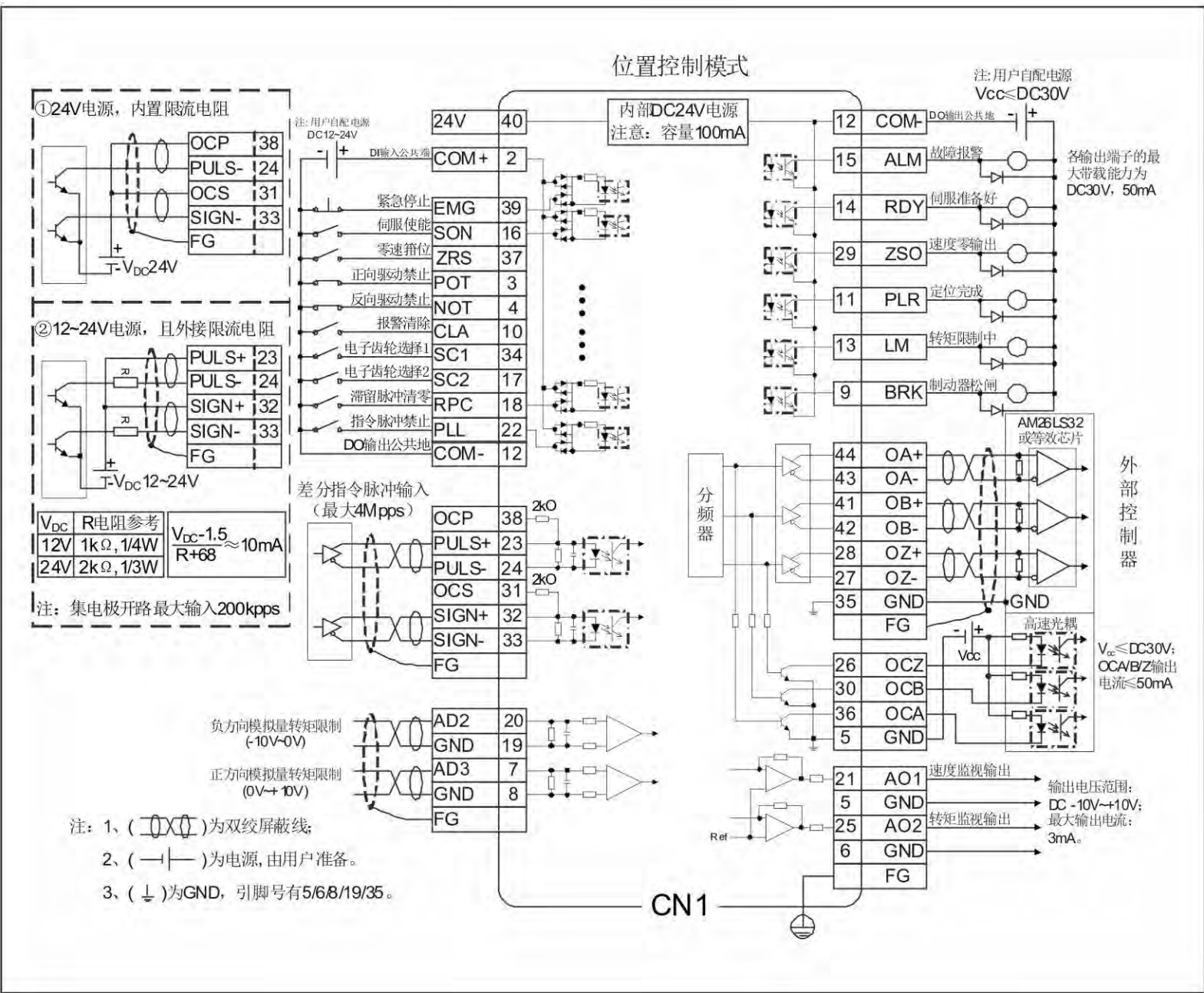

速度控制模式

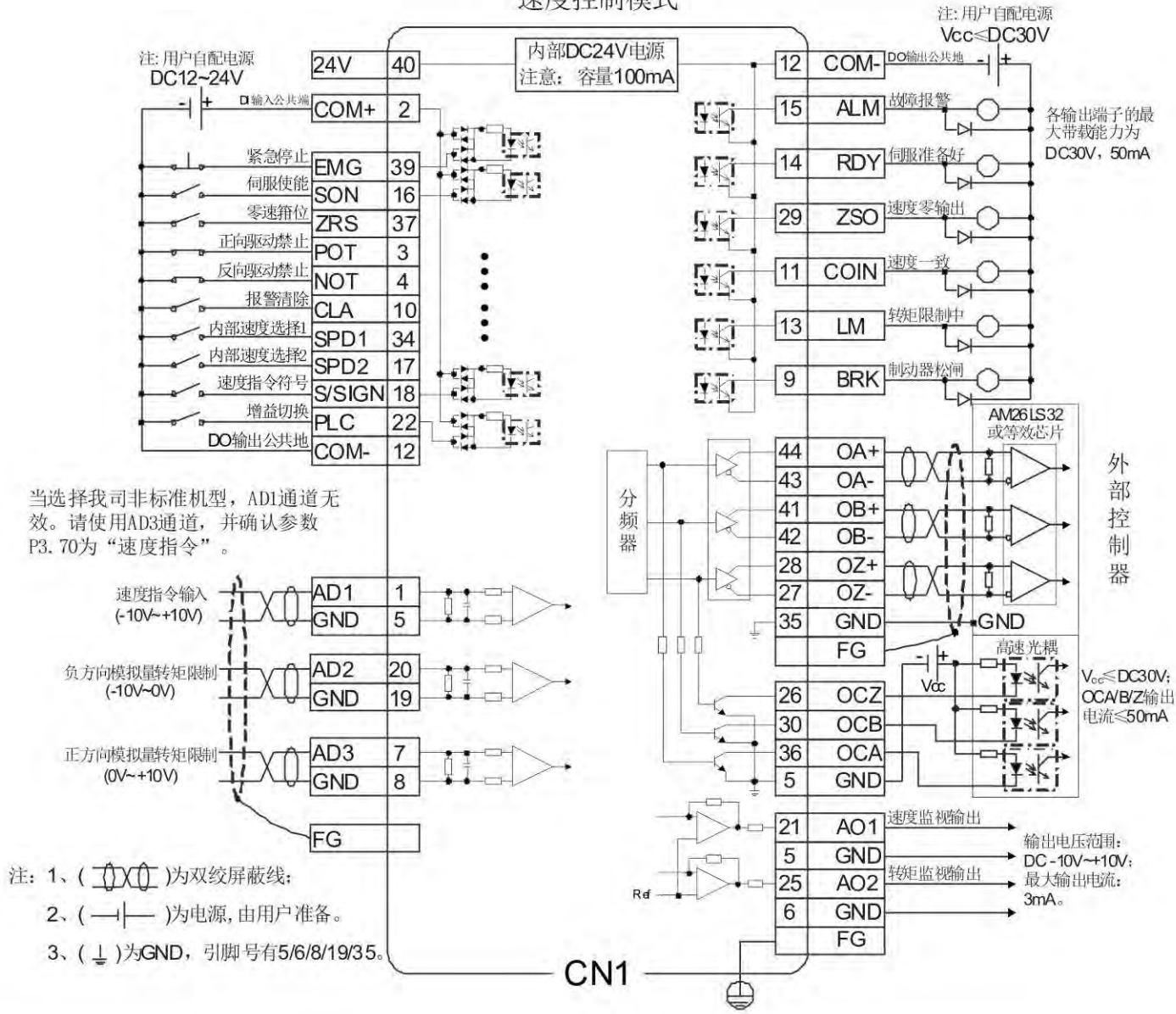

速度模式接线图(适用于模拟量输入控制)
Speed Control Connection(Suit for Analog Input Control)

转矩控制接线图(适用于模拟量输入控制)
Torque Control Connection(Suit for Analog Input Control)

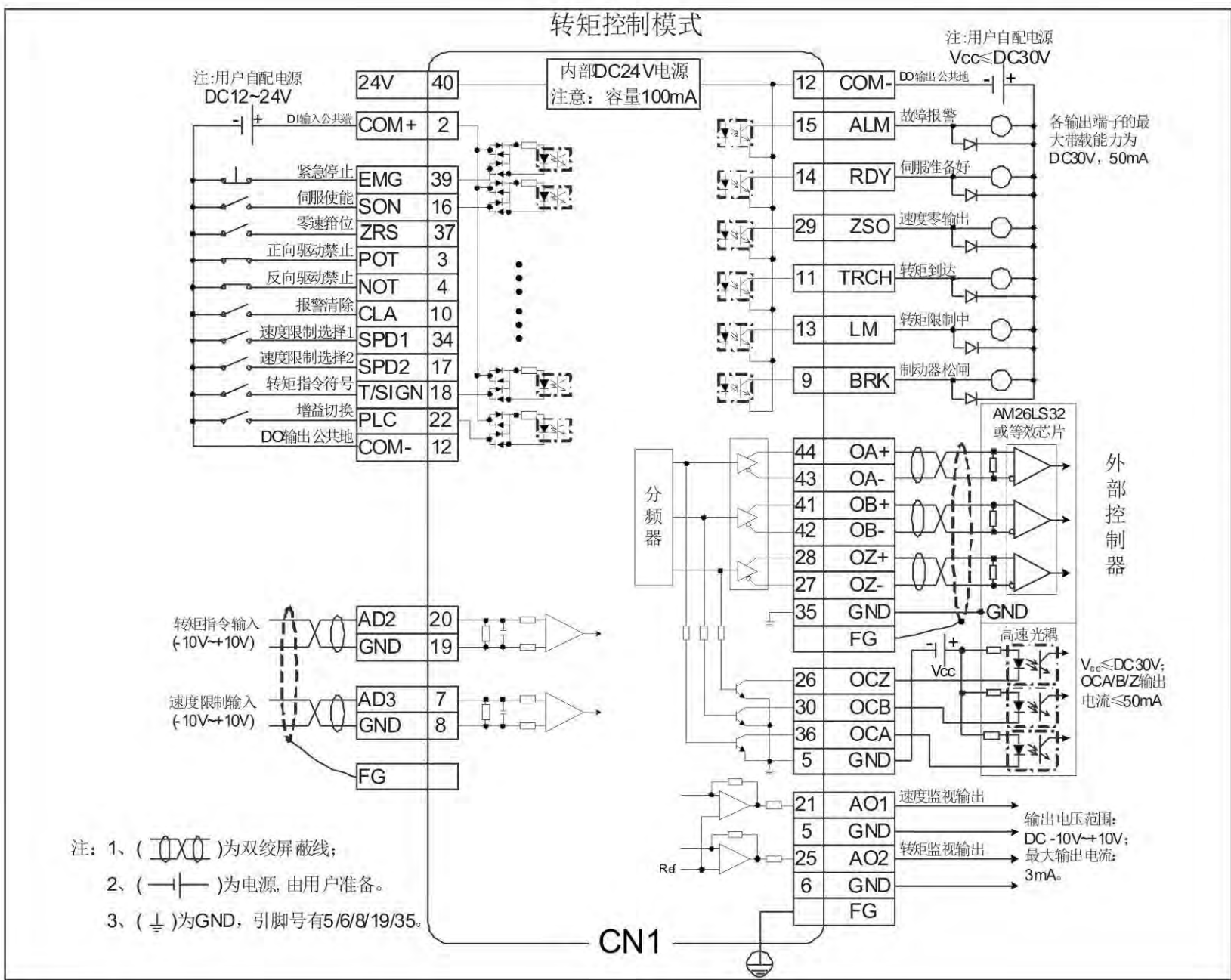

3. 调试软件 ServoPlover Operation Software



便捷友好的操作界面 Convenient and friendly user interface

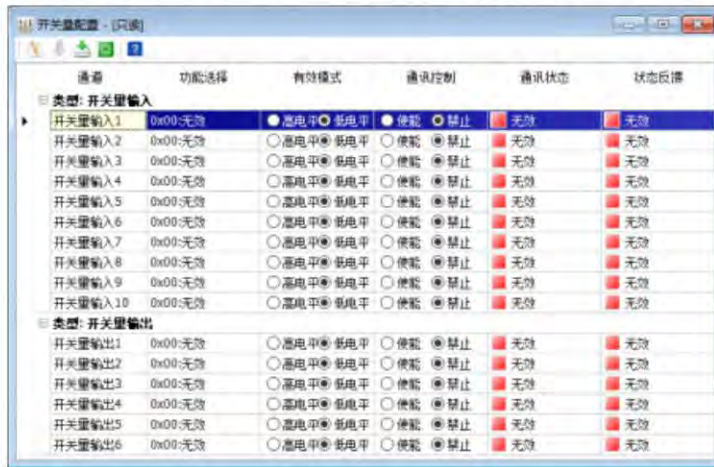

开关量输入、输出可以直接选择端子有效逻辑和功能分配
Digital I/O can directly select effective terminal logic and function distribution



模拟量输入输出可以在图示中设定增益、零偏、死区等参数
Analog I/O can set parameters such as gain, zero offset and deadzone, as shown above

九. 产品附件

Product Accessories

1. 电缆型号说明

Cable Model

电机动力电缆型号说明/Power cable model

DA ML - 075 - 05 - A B 0 - 00

1 2 3 4 5 6 7 8

标识/No.	标识说明/Description	型号说明/Model description
1	产品系列/Model	DA: 厂家使用/JIE use
2	动力电缆/Power cable	ML: 动力线电缆/Power cable
3	线径/Cable diameter	075: 0.75mm ² 150: 1.5mm ² 250: 2.5mm ² 600: 6.0mm ²
4	线缆长度/Cable length	03: 3米/m 05: 5米/m 15: 15米/m
5	电机端插头/Motor side	A: 4PIN塑胶插头/Plastic plug B: 4PIN普通航空插头YD28/Aviation plug C: 4PIN金属插头/Metal plug N: 4PIN普通航空插头YD32//Aviation plug
6	驱动器端插头/Drive side	B: 欧式7PIN 20A插头/European style W: 无插头/Line style
7	电缆材质/Cable material	0: 普通电缆(不带屏蔽)/Without shielding A: 带屏蔽普通电缆(仅限用于7.5kW及以上功率) /With shield only for 7.5kW and above power
8	流水号/Code	00: 标准件/Standard code

电机编码器电缆型号说明/Encoder cable model

DB EL - 15 - 03 - A 0 1 - 00

1 2 3 4 5 6 7 8

标识/No.	标识说明/Description	型号说明/Model description
1	产品系列/Model	DA: 厂家使用/JIE use
2	编码器电缆/Encoder cable	EL: 编码器线电缆/Encoder cable
3	线数/Core	06: 6芯电缆/6 core cable 15: 15芯电缆/15 core cable
4	线缆长度/Cable length	03: 3米/m 05: 5米/m 15: 15米/m
5	电机端插头/Motor side	A: 15PIN DB插头/Plug B: 15PIN普通航空插头YD28/Aviation plug C: 9PIN金属插头Metal plug D: 6PIN塑胶头/Plastic plug
6	电缆材质/Cable material	0: 普通电缆不带电池盒D: 普通电缆带电池盒
7	编码器类型/Encoder type	01: 2500线标准增量式 04: 17位单圈/23位多圈绝对值
8	流水号/Code	00: 标准件/Standard code

2. 电缆配线说明 Cable Description

电机动力电缆配线说明/Motor power cable description

2500线编码器电机60/80法兰规格0.4~0.75kW / 2500ppr encoder flange size 60/80

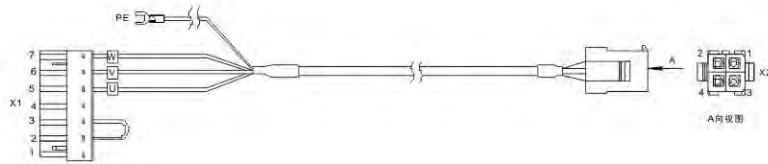

接线关系表/Wiring relationship table

定义/Define	X1	X2	芯线颜色/Core cable color
W	X1.7	X2.3	棕/Brown
V	X1.6	X2.1	红/Red
U	X1.5	X2.2	蓝/Blue
PE	接地/Ground	X2.4	黄/绿Yellow/Green
/	X1.4	/	/
/	X1.3	与X1.2短接/Short circuit with X1.2	
/	X1.2	与X1.3短接/Short circuit with X1.3	
/	X1.1	/	/

17位或23位编码器电机60/80法兰规格0.4~0.75kW / 17bit or 23bit encoder flange size 60/80

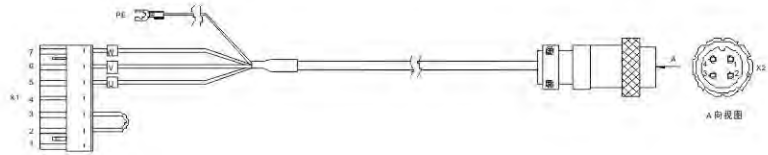

接线关系表/Wiring relationship table

定义/Define	X1	X2	芯线颜色/Core cable color
W	X1.7	X2.1	棕/Brown
V	X1.6	X2.3	红/Red
U	X1.5	X2.4	蓝/Blue
PE	接地/Ground	X2.2	黄/绿Yellow/Green
/	X1.4	/	/
/	X1.3	与X1.2短接/Short circuit with X1.2	
/	X1.2	与X1.3短接/Short circuit with X1.3	
/	X1.1	/	/

130法兰规格1kW~2kW、180法兰规格3kW / 130 flange size 1~2kW、180 flange size 3kW

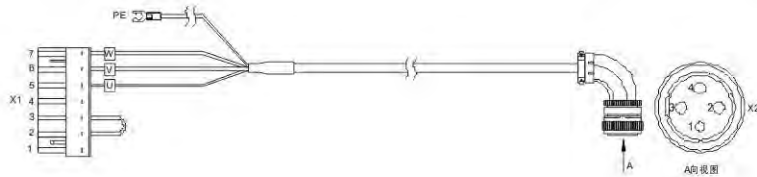

接线关系表/Wiring relationship table

定义/Define	X1	X2	芯线颜色/Core cable color
W	X1.7	X2.4	棕/Brown
V	X1.6	X2.3	红/Red
U	X1.5	X2.2	蓝/Blue
PE	接地/Ground	X2.1	黄/绿Yellow/Green
/	X1.4	/	/
/	X1.3	与X1.2短接/Short circuit with X1.2	
/	X1.2	与X1.3短接/Short circuit with X1.3	
/	X1.1	/	/

180法兰规格4.4kW~7.5kW / 180 flange size 4.4~7.5kW

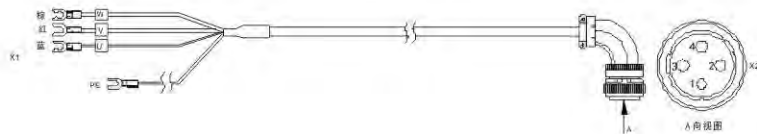

接线关系表/Wiring relationship table

定义/Define	X2	芯线颜色/Core cable color
W	X2.4	棕/Brown
V	X2.3	红/Red
U	X2.2	蓝/Blue
PE	X2.1	黄/绿Yellow/Green

电机编码器电缆配线说明/Motor encoder cable description

2500线编码器电机60、80法兰规格 / 2500ppr encoder flange size 60、80

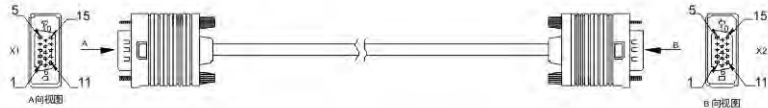

接线关系表/Wiring relationship table

信号/Signal	X1	X2	芯线结构/Structure
V+	X1.1	X2.1	对绞/Twisted pair
V-	X1.7	X2.7	
W+	X1.2	X2.2	对绞/Twisted pair
W-	X1.8	X2.8	
A+	X1.3	X2.3	对绞/Twisted pair
A-	X1.4	X2.4	
U+	X1.6	X2.6	对绞/Twisted pair
U-	X1.11	X2.11	
B-	X1.9	X2.9	对绞/Twisted pair
B+	X1.10	X2.10	
Z-	X1.13	X2.13	对绞/Twisted pair
Z+	X1.14	X2.14	
5V	X1.5	X2.5	对绞/Twisted pair
GND	X1.12	X2.12	
PE	铁壳/Shell	铁壳/Shell	

2500线编码器电机130、180法兰规格 / 2500ppr encoder flange size 130、180

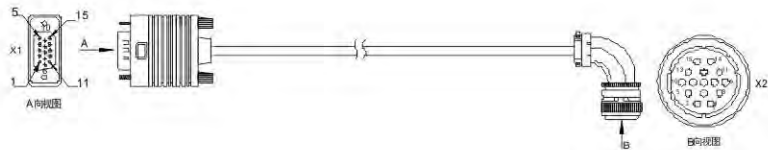

接线关系表/Wiring relationship table

信号/Signal	X1	X2	芯线结构/Structure
V+	X1.1	X2.11	对绞/Twisted pair
V-	X1.7	X2.14	
W+	X1.2	X2.12	对绞/Twisted pair
W-	X1.8	X2.15	
A+	X1.3	X2.7	对绞/Twisted pair
A-	X1.4	X2.4	
U+	X1.6	X2.10	对绞/Twisted pair
U-	X1.11	X2.13	
B-	X1.9	X2.8	对绞/Twisted pair
B+	X1.10	X2.5	
Z-	X1.13	X2.9	对绞/Twisted pair
Z+	X1.14	X2.6	
5V	X1.5	X2.2	对绞/Twisted pair
GND	X1.12	X2.3	
PE	铁壳/Shell	铁壳/Shell	

17位或23位编码器电机60、80法兰规格 / 17bit or 23bit encoder flange size 60、80

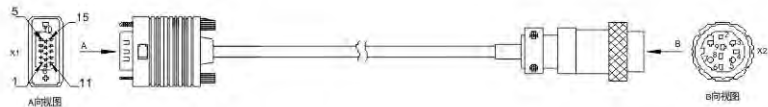

接线关系表/Wiring relationship table

信号/Signal	X1	X2	芯线结构/Structure
SD+	X1.1	X2.1	对绞/Twisted pair
SD-	X1.7	X2.2	
5V	X1.5	X2.3	对绞/Twisted pair
GND	X1.12	X2.4	
VB-5V	/	X2.5	对绞/Twisted pair
VB-GND	/	X2.6	
PE	铁壳/Shell	铁壳/Shell	编织/Braid phy

17位或23位编码器电机130、180法兰规格 / 17bit or 23bit encoder flange size 130、180

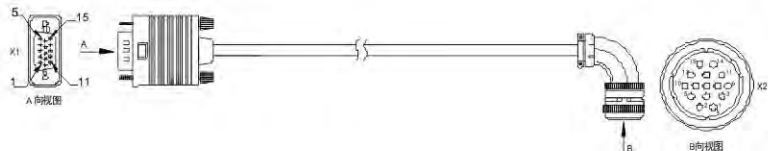

接线关系表/Wiring relationship table

信号/Signal	X1	X2	芯线结构/Structure
SD+	X1.1	X2.2	对绞/Twisted pair
SD-	X1.7	X2.3	
5V	X1.5	X2.4	对绞/Twisted pair
GND	X1.12	X2.5	
VB-5V	/	X2.6	对绞/Twisted pair
VB-GND	/	X2.7	
PE	铁壳/Shell	铁壳/Shell	编织/Braid phy

3. AQS连接盘订购信息 AQS order information

JDC伺服电机与JIE减速机的连接盘
Adapter for servomotor connecting with gear unit

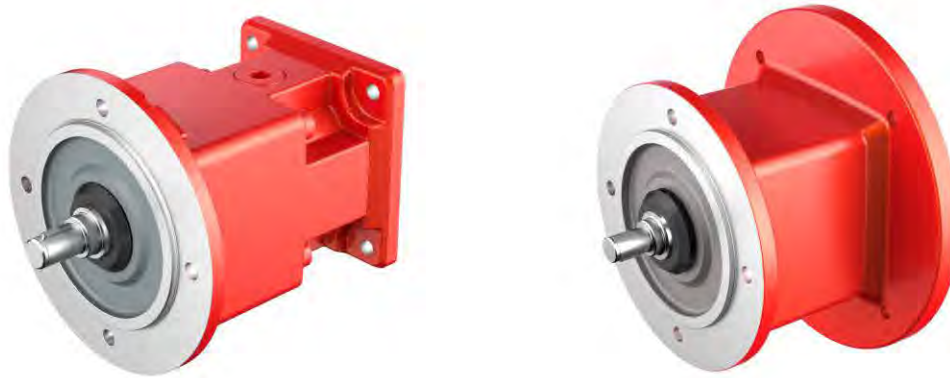

* 详细产品参数敬请查询：JRT 齿轮减速机选型手册，或联系杰牌。

* For more product information, please refer to: JRT Gearmotor selection manual, or please contact JIE.

十. 伺服系统订货指南

Order Information

1. JDC伺服电机选型

JDC Motor Order Information

1. JDC伺服电机选型/Servo motor selection										
序号 No.	电压等级 Voltage	额定功率 Power (kW)	额定转速 Speed (r/min)	额定扭矩 Torque (Nm)	法兰规格 Flange (mm)	型号 Type				
1	220V	0.4	3000	1.27	60×60	JDC60L-400302	<input type="checkbox"/>	-	<input type="checkbox"/>	OKA
2		0.75	3000	2.39	80×80	JDC80L-750302	<input type="checkbox"/>	-	<input type="checkbox"/>	OKA
3		1.0	2000	4.78	130×130	JDC130M-1K0202	<input type="checkbox"/>	-	<input type="checkbox"/>	OKA
4		1.5	2000	7.16		JDC130M-1K5202	<input type="checkbox"/>	-	<input type="checkbox"/>	OKA
5	380V	1.0	2000	4.78	130×130	JDC130M-1K0204	<input type="checkbox"/>	-	<input type="checkbox"/>	OKA
6		1.5	2000	7.16		JDC130M-1K5204	<input type="checkbox"/>	-	<input type="checkbox"/>	OKA
7		2.0	2000	9.55		JDC130M-2K0204	<input type="checkbox"/>	-	<input type="checkbox"/>	OKA
8		180×180	3.0	1500	19	JDC180M-3K0154	<input type="checkbox"/>	-	<input type="checkbox"/>	OKA
9			4.4	1500	27	JDC180M-4K4154	<input type="checkbox"/>	-	<input type="checkbox"/>	OKA
10			5.5	1500	35	JDC180M-5K5154	<input type="checkbox"/>	-	<input type="checkbox"/>	OKA
11			7.5	1500	48	JDC180M-7K5154	<input type="checkbox"/>	-	<input type="checkbox"/>	OKA
编码器类型(可选) Encoder options		TTL 2500线增量编码器 Incremental encoder TTL 2500ppr					T			
		17位单圈绝对值编码器 ^① 17bits Single-turn absolute encoder					H			
		23位多圈绝对值编码器 23bits Multi-turn absolute encoder					M			
抱闸 ^② (可选) Brake options		不带抱闸 Without brake								A
		带抱闸 ^③ With brake								B

说明:

① 17单圈绝对值编码器只适用于上表格序号1、2、3三款电机，且无带抱闸选项。

② 所有电机输出轴端：标配油封、标配带键轴、标配轴中心螺纹孔。

③ 如选用带抱闸电机，抱闸电机接插件将随箱发运，请客户自备抱闸电缆。

Note:

① 17bit absolute encoder only for No.1、2、3 servo motor, and no with brake option.

② All motor shaft end with oil seal, with shaft key, and with shaft center hole.

③ If select brake motor, the brake connector will on the motor, brake cable can be made by customer.

2. JCS伺服驱动器选型

JCS Servo Drive Order Information

2. JCS伺服驱动器选型/Servo drive selection							
序号 No.	电压等级 Voltage	额定功率 Power (kW)	输出电流 Current (A)	外形尺寸 规格 Frame	型号 Type		
1	220V	0.4	3.3	A	JCS500-0K4-2V-	<input type="checkbox"/>	0A1S
2		0.75	4.5	B	JCS500-0K7-2V-	<input type="checkbox"/>	0A1S
3		1.0	5.0		JCS500-1K0-2V-	<input type="checkbox"/>	0A1S
4		1.5	7.6		JCS500-1K5-2V-	<input type="checkbox"/>	0A1S
5	380V	1.0	3.5	B	JCS500-1K0-4V-	<input type="checkbox"/>	0A1S
6		1.5	4.5		JCS500-1K5-4V-	<input type="checkbox"/>	0A1S
7		2.0	6.5	C	JCS500-2K0-4V-	<input type="checkbox"/>	0A1S
8		3.0	8.5		JCS500-3K0-4V-	<input type="checkbox"/>	0A1S
9		4.4	12	D	JCS500-4K4-4V-	<input type="checkbox"/>	0A1S
10		5.5	16		JCS500-5K5-4V-	<input type="checkbox"/>	0A1S
11		7.5	25		F	JCS500-7K5-4V-	<input type="checkbox"/>
驱动器版本类型 Drive version					脉冲序列(PTI)版本 Plus train	<input type="checkbox"/>	E
					EtherCAT总线型 EtherCAT version	<input type="checkbox"/>	N
					PROFINET总线型 PROFINET version	<input type="checkbox"/>	PN
					标准型(该代码:仅限7.5kW使用) Standard version only for 7.5kW drive	<input type="checkbox"/>	S

说明:

- ① 可依据上表格中第1列的'序号'栏进行驱动器与电机的型号配对。
- ② 第42页的电缆选型也可通过表格中的第1列的'序号'栏与电机进行匹配。

Note:

- ① For drive match with motor, can refer to the number of column 1 'No.'
- ② For cable(Page42) match with motor, also can refer to the number of column 1 'No.'

3. 配套电缆选型 Cable Order Information

3. 电缆选型(伺服驱动器与伺服电机连接)/Cable connection for drive and motor														
序号 No.	动力电缆标准型 Power cable Standard type				2500线增量编码器电缆 标准型 TTL encoder cable Standard type			17或23位绝对值编码器电缆 标准型 Absolute encoder cable Standard type			17或23位绝对值编码器电缆 带电池盒 Absolute encoder cable With battery type			
1	DAML-075-	□	-	□	-00	DBEL-15-	□	-A0-0100	DBEL-06-	□	-C0-0400	DBEL-06-	□	-CD-0400
2														
3	DAML-150-	□	-	BB0	-00	DBEL-15-	□	-B0-0100	DBEL-06-	□	-B0-0400	DBEL-06-	□	-BD-0400
4														
5														
6														
7														
8														
9	DBML-250-	□	-	NWO	-00									
10														
11	DBML-600-	□	-	NWA	-00									

长度:3米 Length:3m	03
长度:5米 Length:5m	05
长度:15米 Length:15m	15

长度:3米 Length:3m	03
长度:5米 Length:5m	05
长度:15米 Length:15m	15

长度:3米 Length:3m	03
长度:5米 Length:5m	05
长度:15米 Length:15m	15

长度:3米 Length:3m	03
长度:5米 Length:5m	05
长度:15米 Length:15m	15

增量型编码器电机 TTL encoder motor	AB0
绝对值编码器电机 Absolute encoder motor	CB0

说明:

- ① 可依据上表格中第1列的'序号'栏进行电缆与电机的型号配对。
- ② 绝对值编码器如需断电位置记忆功能, 请选择‘带电池盒’型电缆。

Note:

- ① For cable match with motor, can refer to the number of column 1 'No.'
- ② If need location memory function, please select the cabel with battery type.

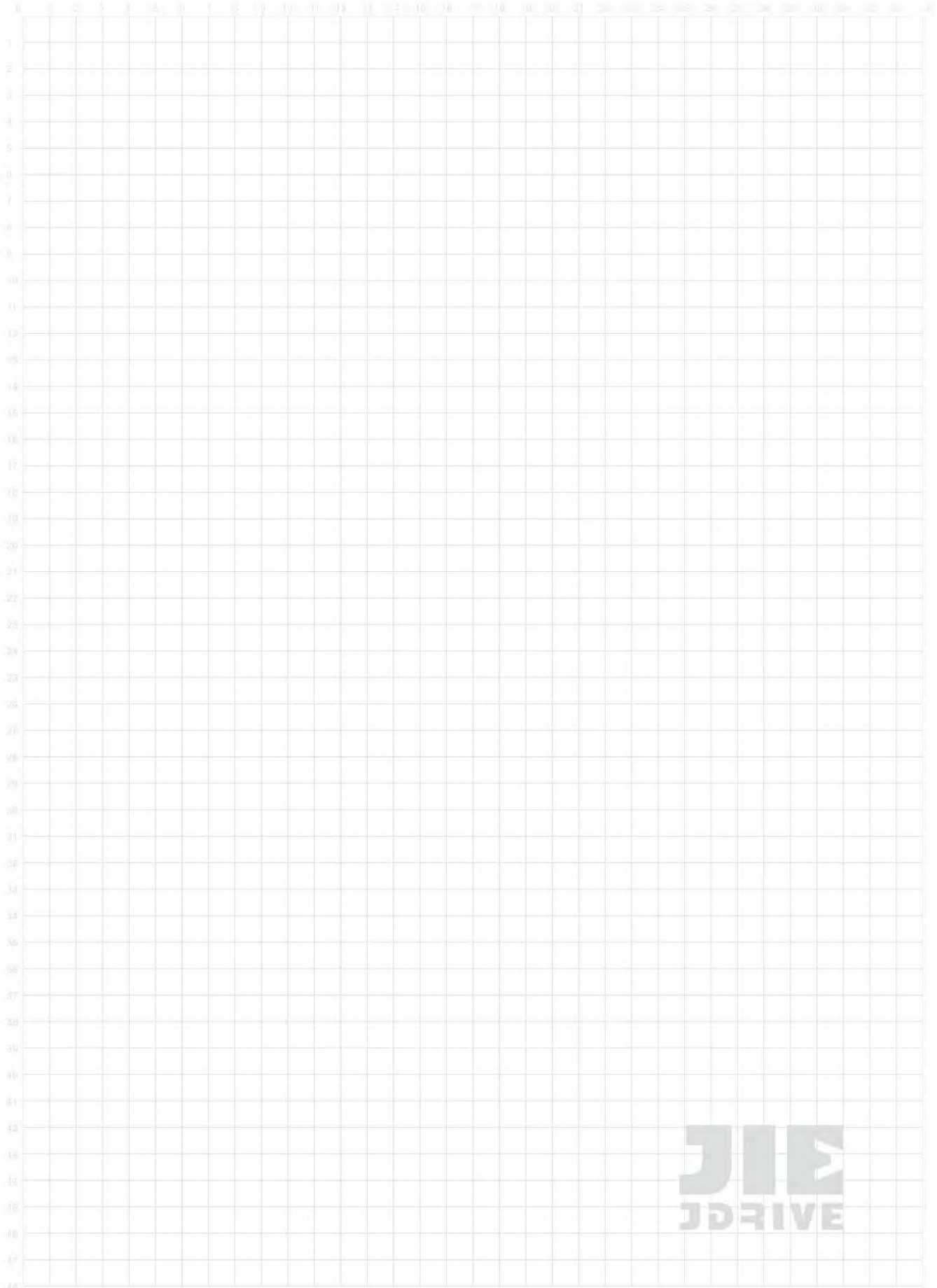

杰牌传动产品目录

JIE DRIVE

PRODUCT CATALOGUE

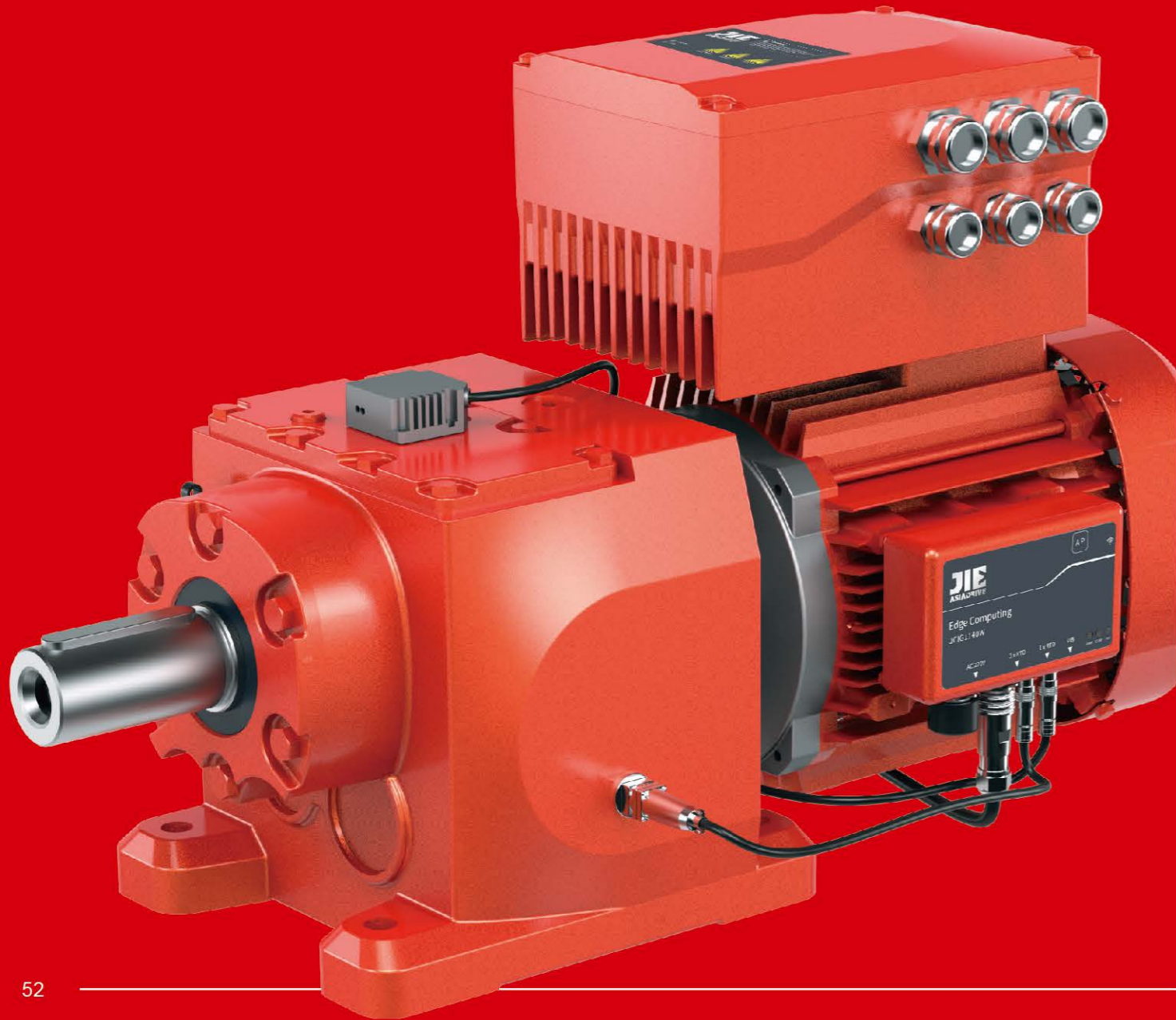

JRT 齿轮减速电机



JRTR
齿轮减速电机
规格: 17~187
传动比: 3.37~289.74
输入功率: 0.12~250 kW
输出扭矩: 2.4~56494 Nm



JRTF
平行轴-齿轮减速电机
规格: 37~167
传动比: 3.77~281.71
输入功率: 0.12~250kW
输出扭矩: 3.5~37125Nm



JRTK
锥齿轮-齿轮减速电机
规格: 37~187
传动比: 3.98~197.37
输入功率: 0.12~200kW
输出扭矩: 10~62800Nm



JRTR
蜗杆副-齿轮减速电机
规格: 37~97
传动比: 6.8~288
输入功率: 0.12~22kW
输出扭矩: 10~4900Nm



JRTRX
齿轮减速电机
规格: 57~107
传动比: 1.3~8.65
输入功率: 0.12~45kW
输出扭矩: 1.4~990Nm

JRH 工业齿轮箱



JRHH
平行轴齿轮箱
规格: 3~28
传动比: 1.25~450
输入功率: 4.3~10515kW
输出扭矩: 2300~1400000Nm



JRHB
直轴轴齿轮箱
规格: 4~28
传动比: 5~400
输入功率: 2.8~4908kW
输出扭矩: 5500~1400000Nm



JRHD
斗提机齿轮箱
规格: 5~16
传动比: 25~71
输入功率: 16~1305kW
输出扭矩: 11000~173000Nm



JRHO
棕榈油齿轮箱
规格: 310
传动比: 56、80
输入功率: 106、141kW
输出扭矩: 75000Nm



JRHA
空冷岛齿轮箱
规格: 166
传动比: 14
输入功率: 228kW
输出扭矩: 21000Nm

JRP 行星齿轮箱



JRP
大型行星齿轮箱
规格: 9~36
传动比: 25~4000
输入功率: 0.4~12934kW
输出扭矩: 22000~2600000Nm



JRP
小型行星齿轮箱
规格: 01~8
传动比: 3.08~3460
输入功率: 0.02~192kW
输出扭矩: 1000~13000Nm



JRP
行星齿轮箱
规格: 08~100
传动比: 3.4~2000
输入功率: 75~250kW
输出扭矩: 8000~100000Nm



VR
同心轴行星减速机
速比: 3~100
背隙: 1~3/3~5/5~7/3arc-min
扭矩: 6~3300Nm



EV
直角行星减速机
速比: 3~100
背隙: 4~9/6~11arc-min
扭矩: 12~1920Nm

JRW 蜗杆减速机



JRW
蜗杆减速机
规格: 30~150
传动比: 7.5~100
输入功率: 0.1~25.8kW
输出扭矩: 13~1550Nm



JRWD
蜗杆减速机
规格: 25~150
传动比: 7.5~100
输入功率: 0.06~15kW
输出扭矩: 2.6~1760Nm



JRW
NEMA蜗杆减速机
规格: 30~150
传动比: 7.5~100
输入功率: 0.06~15kW
输出扭矩: 2.6~1760Nm



WPA
蜗杆减速机
规格: 40~250
传动比: 10~60
输入功率: 0.12~33.2kW
输出扭矩: 19~2745Nm



WPW
蜗杆减速机
规格: 40~250
传动比: 10~60
输入功率: 0.12~33.2kW
输出扭矩: 6~3025Nm

JD 电动机



JD
IEC电机
规格: 63~315
功率: 0.12~200kW
能效: IE2、IE3、IE4 (0.75~200kW)



JDP
NEMA电机
规格: 63~315
功率: 0.12~200kW
能效: IE2、IE3、IE4 (0.75~200kW)



JDN
NEMA电机
规格: 63~180
功率: 0.12~22kW
能效: IE2、IE3、IE4



JDB
防爆电机
规格: 80~315
功率: 0.75~200kW
防爆等级: Exib II BT4
能效: IE2、IE3



JDC
伺服电机
规格: 30~90
功率: 0.4~7.5kW
额定扭矩: 1.27~48Nm

JC 智能传动方案



JC
智能传动方案
减速机+电动机+变频器
+传感器+物联网等行业传动方案



JCI
智能监测系统
监测项目: 振动、温度、湿度、
气压、电压、电流、地理位置等



JCM
变频一体减速机
规格: 004~0075
功率: 0.4~7.5kW
防护等级: IP54~IP65
供电: 3AC 380~440V
输出频率: 0~200Hz



JCF
变频器
规格: 0075~0550
功率: 0.75~55kW
输出频率: 0~200Hz
载波频率: 8~32KHz



JCS
伺服驱动器
规格: FSA/FSB/FSC
功率: 0.4~7.5kW
供电: 1AC 220V/3AC 380V

其它减速机



JRESR
不锈钢齿轮减速电机
规格: 37~67
传动比: 3.41~199.81
输入功率: 0.18~7.5kW
输出扭矩: 26~670Nm



JRESK
锥齿轮-不锈钢齿轮减速电机
规格: 37~67
传动比: 3.98~145.14
输入功率: 0.18~5.5kW
输出扭矩: 12~910Nm



JRESS
不锈钢蜗杆减速机
规格: 40~90
传动比: 7.5~100
输入功率: 0.09~4kW
输出扭矩: 19~458Nm



JRSS
螺杆升降机
规格: 35~150
传动比: 5~40
输入功率: 0.19~16.3kW
起升力: 500~26050kg



JRTM
锥齿轮转向器
规格: 2~25
传动比: 1~5
输入功率: 0.014~335kW
输入转速: 10~1450r/min



JRGC
工程分动箱
规格: 0401、1501
传动比: 0.589、0.659、0.756、0.825
输出最大扭矩: 1390Nm
行走最大扭矩: 40000Nm



JTA
轴装式减速机
规格: 80/90~100/120
速比: 5~31.5
功率: 11~45kW
扭矩: 6600~10500Nm



JEC
扶梯主机
规格: 2~15、2~25
传动比: 24.5
效率: ≥96%
使用寿命: 146000h
输出扭矩: 3530~5150Nm



JN
农机齿轮箱
传动比: 0.364~2.33
输入转速: 800r/min
效率: ≥96%



杰牌智能传动方案提供商
更多产品敬请咨询

杰牌智能传动平台产品

Platform Products of JIE Intelligent Drive

产品标准化实现平台化, 工艺标准化实现自动化, 流程标准化实现信息化。

Standardizing the products to realize platformization, Standardizing the technologies to realize automation, Standardizing the processes to realize informatization.

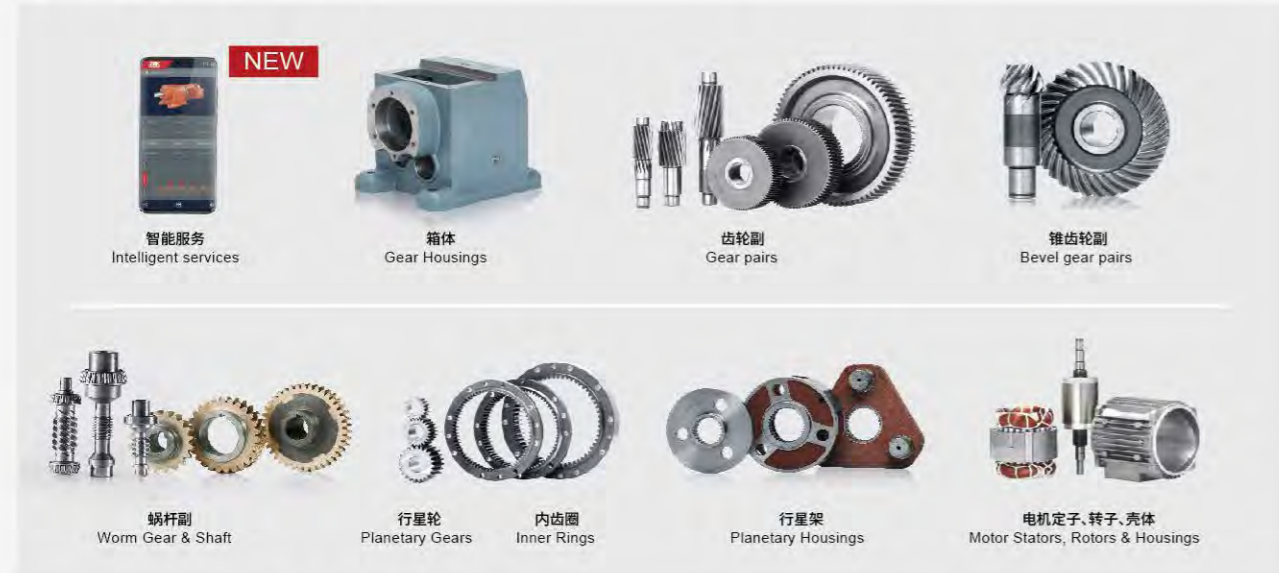

杰牌智能传动项目应用案例

An application case of JIE Intelligent Drive Solutions

智能计划物流、箱体智能工厂、齿轮智能工厂、电机智能工厂、装配智能工厂、智能检测试验等项目传动方案。

Projects Drive Solutions incl. Intelligent Planning Logistics, Intelligent Plant of Gear Housings, Intelligent Plant of Gears, Intelligent Plant of Motors, Intelligent Plant of Assembly, Intelligent Tests, etc.

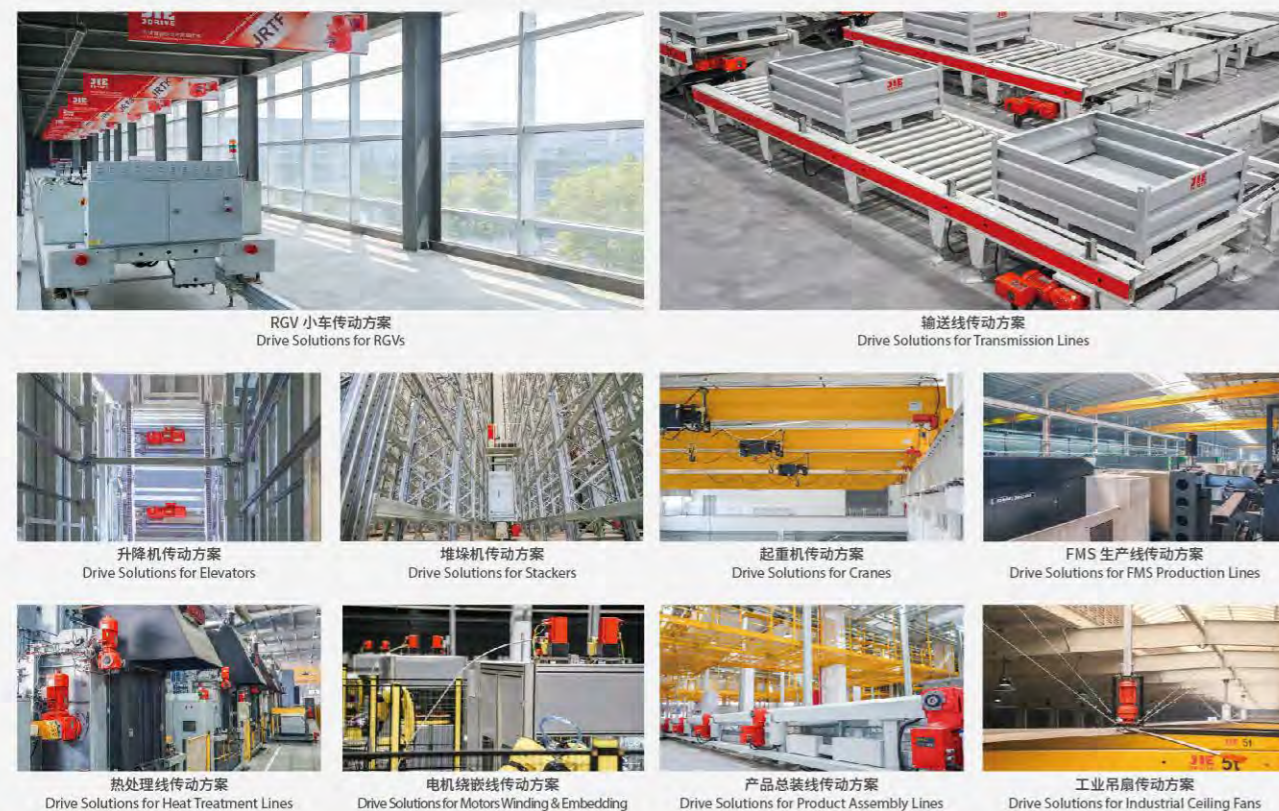

杰牌智能传动项目

JIE Intelligent Drive Project

智能工厂+智能产品+智能服务, 推进精益生产, 建设智能工厂, 构建产业联盟, 实现合作共赢。

Intelligent Plants + Intelligent Products + Intelligent Services, to promote lean production and build intelligent plants, and to build industrial alliances and achieve win-win cooperation.



杰牌智能传动行业应用案例

Industrial application cases of JIE Intelligent Drive Solutions

杰牌“新、衣、食、住、行、源、运”等行业传动方案。

JIE Industrial Drive Solutions for New Manufacturing, Clothing, Food, Residence, Traveling, Energy, Transportation, etc.

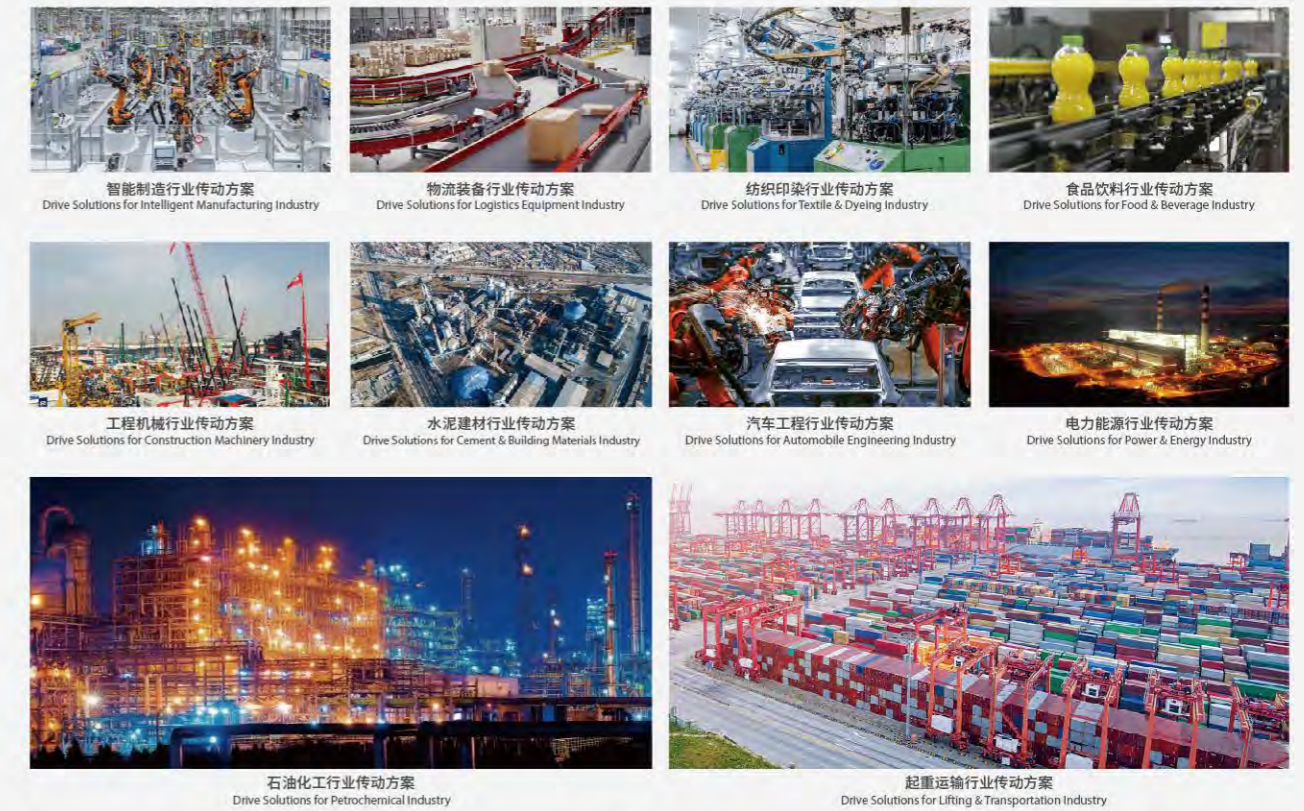

杰牌智能传动工业园

JIE Intelligent Drive Industrial Zone

生产区: 1号工厂、2号工厂、3号工厂、万杰工厂、5号工厂; 办公区: A座商务中心、B座创新中心、C座运营中心; 生活区: 匠心楼、群英楼、精益楼。

Production Area: No.1 Plant, No.2 Plant, No. 3 Plant, Wanjie Plant, No. 5 Plant;
Office Area: Building A Business Center, Building B Innovation Center, Building C Operation Center;
Living Area: Artisans Building, Elites Building, Lean Building.



杰牌智能传动方案提供商

JIE Intelligent Drive Solutions Provider

杰牌智能传动项目应用智能产品、建设智能工厂、生产智能产品, 为用户提供智能产品、智能服务、智能体验, 实现一台减速机的智能制造之旅和智能监测运维。

JIE Intelligent Drive Project, which applies intelligent products to build intelligent plants and produce intelligent products, to serve the customers with intelligent products, intelligent services and intelligent experience, has realized a journey of intelligent manufacturing, intelligent operation & maintenance monitoring for a reducer.



杰牌研产销服一体化平台

JIE Platform integrated with research, production, supply, marketing and service

全流程的生态系统、多系统的数据中台、一体化的工业大脑。

A whole-process ecosystem, A multi-system data center and an integrated industrial brain.



杰牌美丽工厂

JIE Beautiful Plants

打造“环境友好型、发展持续性、服务全球型”的小而美公司。

To build a small but excellent company of "Environment-friendly, Sustainable and Global service".



在专业化的路上走向胜利 On road to specialization strive together

陈 杰 词
Lyric: Chen Jie
钱建隆 曲
Music: Qian JianLong

1 = bE $\frac{4}{4}$

稍快、朝气蓬勃地
allegretto, full of youth

||: ($\overset{3}{111}$ $\overset{3}{111}$ $\overset{3}{111}$ 1 | $\overset{3}{111}$ $\overset{3}{111}$ $\overset{3}{111}$ 1 | $\underline{51123456}$ | $\overset{3}{5} \underline{555}$ 1 0) |

$\underline{5}$ 1 1 2 3 1 0 | $\underline{5 \cdot 4}$ 3 2 3 1 0 | i \cdot $\underline{7}$ $\underline{7}$ $\underline{6}$ $\underline{6}$ 5 | 6 5 3 4 5 - |

要做 就做 一流 是我 永恒 追求 产业 联盟 我们 一起 走
To be the star is my eternal pursue industrial union we walk together
产业 事业 家业 共同 富裕 和谐 目标 在 前 我们 一起 走
Estate career family harmonious with wealth for the goal ahead we walk together

$\underline{5}$ 1 1 2 3 1 0 | $\underline{5 \cdot 4}$ 3 2 3 1 0 | $\bar{1}$ \bar{i} $\bar{7}$ $\bar{6}$ | $\underline{5 \cdot 4}$ 3 4 2 \vee 1 |

聚 万物 之灵 造 天地 之杰 产业 发 展 我们 一起 走 啦
Nimbus from all beings making it outstanding industry developing we walk together La

团结 创新 专业 推动 联盟 发展 胜利 在 前 我们 一起 走 啦
Join Innovation Expertise enhancing the union for the victory ahead we walk together La

i - \underline{i} \underline{i} $\underline{7}$ \underline{i} | 5 - - 1 | 6 - $\underline{6}$ $\underline{6}$ $\underline{7}$ \underline{i} 3 - - - |

啦 啦 啦 啦 啦 啦 啦 啦 啦 啦 啦 啦
La La La La La La La La La La

(节奏强烈、有冲击力)
(hot, powerful)

1 - 4 5 | $\underline{6 \cdot 7}$ \underline{i} 6 \cdot 5 | 6 6 $\underline{5 \cdot 4}$ 3 5 | 5 - - - |

在 专 业 化 的 路 上 我 们 一 起 努 力
On road to specialization we strive together

1 - 4 5 | $\underline{6 \cdot 7}$ \underline{i} 6 \cdot 5 | 4 3 $\underline{2 \cdot 2}$ 1 2 | 2 - - - |

在 专 业 化 的 路 上 我 们 走 向 胜 利
On road to specialization we go to victory

1 - 4 5 | $\underline{6 \cdot 7}$ \underline{i} 6 \cdot 5 | 6 6 $\underline{5 \cdot 4}$ 3 6 | 6 - - - |

在 专 业 化 的 路 上 我 们 一 起 努 力
On road to specialization we strive together

1 - 4 5 | $\underline{6 \cdot 7}$ \underline{i} 6 \cdot 5 | $\overset{1}{4}$ 3 $\underline{2 \cdot 2}$ 3 1 | 1 - - - ||

在 专 业 化 的 路 上 我 们 走 向 胜 利
On road to specialization we go to victory

- 2 -
4 3 $\underline{2 \cdot 2}$ 3 1 | 1 0 0 $\overset{>}{i}$ | $\overset{>}{i}$ - 0 0 | 0 0 0 0 ||

我 们 走 向 胜 利 胜 利
we go to victory Victory